



LEICA M10-P
Instruction manual

FOREWORD

Dear Customer,

We wish you a great deal of fun and success taking photographs with your new Leica M10-P. Please read this manual thoroughly to ensure that you familiarize yourself with the full scope of functions your camera has to offer.

Your Leica Camera AG

SCOPE OF DELIVERY

Before using your camera for the first time, please check that the accessories supplied are complete.

- Leica M10-P
- Camera bayonet cover
- Lithium-ion battery Leica BP-SCL 5
- Battery charger Leica BC-SCL 5, incl. mains cable and in-car charger cable
- Carry strap
- Drawstring pouch for battery, charger and cables
- Manual (this book)
- Test certificate
- Registration card

Subject to changes in design and production.

REPLACEMENT PARTS/ACCESSORIES

Please visit the Leica Camera AG website for information on the extensive range of Leica replacement parts/accessories:

us.leica-camera.com/Photography/Leica-M/Technical-Equipment

Important

- Only the accessories listed and described by Leica Camera AG must be used with the Leica M10-P.

Only the accessories specified and described in this manual or by Leica Camera AG must be used with the camera (battery, charger, mains plug, mains cable, etc.). These accessories should only be used with this product. Third-party accessories may result in malfunctions or damage to the product.

Please make sure to read the chapters “Legal information”, “Safety remarks”, and “General information” before using your camera for the first time. Knowledge of the content will prevent inadvertent damage to the product and possible injuries and other risks.

LEGAL NOTES

LEGAL NOTES

- Compliance with copyright laws is mandatory. The recording and publication of pre-recorded media like tapes, CDs or other published or broadcast material may breach copyright laws.
- The following applies for all video material created with this camera: This product is governed by the AVC Patent Portfolio license and is meant for private use by a consumer only. The device may furthermore be used for purposes for which the consumer receives no remuneration, e.g. (i) encoding in accordance with the AVC Standard (“AVC Video”) and/or (ii) decoding of AVC Video that was encoded by a consumer in accordance with the AVC Standard within the scope of personal use and/or which the consumer has received from the provider, who is in possession of a license to offer AVC Video. No license is granted or implied for any other use. Any other use, specifically the provision of AVC video in exchange for remuneration, may require a separate license agreement with MPEG LA, L.L.C. Please visit the MPEG LA, L.L.C. website at: www.mpegla.com for more information.

REGULATORY INFORMATION

You will find the manufacturing date of your camera on the stickers in the Warranty Card and/or on the packaging.
The date format is year/month/day.

Specific regional approvals for this device can be found in the camera menu.

Select **Camera Information** in the main menu

Select **Regulatory Information** in the submenu

The CE mark on our products documents compliance with the fundamental requirements of applicable EU directives.



DISPOSAL OF ELECTRIC AND ELECTRONIC EQUIPMENT

(Applies within the EU and for other European countries with active waste separation policies.)

This device contains electric and/or electronic components which must not be disposed of in general household waste. Instead, it should be disposed of at a recycling collection point provided by your local authority.

This service is free of charge. Any standard or rechargeable batteries used in this device must be removed and disposed of separately in accordance with local regulations.

Please contact your local authorities, waste disposal collection point or the retailer, from whom you purchased the device for more information on correct waste disposal.

English

Declaration of Conformity (DoC)

Hereby, "Leica Camera AG" declares that this product is in compliance with the essential requirements and other relevant provisions of Directive 2014/53/EU.

Customers can download a copy of the original DoC to our RE products from our DoC server:

www.cert.leica-camera.com

In case of further questions, please contact:

Leica Camera AG, Am Leitz-Park 5, 35578 Wetzlar, Germany

Wireless transmitter:

Frequency range used:

2412 MHz to 2462 MHz (Central frequency - WLAN)

2402 MHz to 2480 MHz (Central frequency - Bluetooth® wireless technology)

Max. output power: 20 dBm (ERP)

The CE mark on our products documents compliance with the fundamental requirements of applicable EU directives.

IMPORTANT NOTES REGARDING THE USE OF GPS

Legal restrictions on use

- The use of GPS and associated technologies may be restricted in some countries or regions.
- You should therefore contact your travel agent or the embassy of your destination country for relevant information beforehand.
- The People's Republic of China and Cuba (exceptions: Hong Kong and Macao) prohibit the use of GPS within their territories and in the vicinity of their borders.

Violations will be prosecuted by local authorities. The GPS function is therefore automatically deactivated in these areas.

Notes on function

- Prerequisite for GPS triangulation is "Line of Sight" (LoS) to at least 3 GPS satellites (up to 9 of the total 24 GPS satellites are available from any point on Earth at all times). The camera should therefore always be held with the GPS antenna pointing straight upwards.
- Make sure not to cover the GPS antenna with your hand or any object (specifically metallic objects).
- Perfect signal reception from GPS satellites may be impossible in the following locations or under the circumstances listed below. Geo-location may then be impossible or erratic at best.
 - in enclosed spaces
 - underground
 - under trees
 - in a moving vehicle
 - in the vicinity of tall buildings or in narrow valleys
 - in the vicinity of high-voltage lines
 - in tunnels
 - in the vicinity of mobile phones
 - with an accessory attached to the flash shoe, e.g. a flash unit

We recommend recommissioning the GPS function in a location with good signal reception if the camera has not been used for an extended period of time.

Notes on safe use

The electromagnetic radiation generated by the GPS system may affect electronic instruments and measuring devices. Make sure to disable the GPS function on board an aircraft before takeoff or landing, in hospitals and other locations where RF restrictions apply.

IMPORTANT NOTES REGARDING THE USE OF WLAN

- Appropriate measures must be taken to ensure security and protect against disruptions to the systems in place where devices or computer systems are in use that require more stringent security than WLAN devices.
 - Leica Camera AG shall not accept liability for damages arising from the use of the camera for purposes other than as a WLAN device.
 - It is assumed that the WLAN function will be used in countries where this camera is sold. There may be a risk of breaching statutory wireless communication regulations when using the camera in other countries. Leica Camera AG shall not accept liability for such breaches.
 - Please note that there is a risk of unauthorized third party interception of wirelessly communicated data. We highly recommend that you activate encryption in the wireless access point settings to ensure data safety.
 - Avoid using the camera in areas where it can be exposed to magnetic fields, static electricity or other interferences, e.g. near a microwave oven. RF transmissions may otherwise not reach the camera.
 - Using the camera near devices like microwave ovens or wireless phones that use the 2.4 GHz RF band may negatively affect the performance of both devices.
 - Do not attempt to connect to wireless networks you are not authorized to use.
- The device will automatically search for wireless networks, once the WLAN function is enabled. A list of network SSIDs, including networks you are not authorized to access, will be displayed (SSID: Network identifier for a WLAN connection). Do not attempt to connect to such a network, as this could be construed as unauthorized access.
 - We recommend disabling the WLAN function while on an aircraft.

SAFETY REMARKS

GENERAL INFORMATION

- Do not use your camera in the immediate vicinity of devices that generate powerful magnetic, electrostatic or electromagnetic fields (e.g. induction ovens, microwave ovens, television sets or computer screens, video game consoles, cell phones, broadcasting equipment). Their electromagnetic fields can interfere with recordings.
- Strong magnetic fields, e.g. from speakers or large electric motors, can damage the stored picture data or disrupt recording.
- Switch off the camera, remove the battery and switch the camera back on if the camera malfunctions due to the effects of electromagnetic fields.
- Do not use the camera in the immediate vicinity of radio transmitters or high-voltage power lines. Their electromagnetic fields can also interfere with recordings.
- Always store small parts e.g. the accessory shoe cover as follows:
 - out of the reach of children
 - in a safe location, where they will not get lost or stolen
- State-of-the-art electronic components are sensitive to static discharge. You can easily pick up charges of several 10,000 volts by simply walking on synthetic floor coverings. A static discharge can occur when you touch the camera, and especially if it is placed on a conductive surface. A static discharge on the camera housing poses no risk for the electronics. Despite built-in safety circuits, you should avoid direct contact with external camera contacts like those in the flash shoe.
- Take care not to soil or scratch the sensor for lens detection in the bayonet. You must similarly prevent direct contact of the bayonet with grains of sand or similar particles, as these could cause irreparable damage. This camera component must only be cleaned with a dry cloth.
- Use a cotton or linen cloth instead of an optical micro-fiber cloth (synthetic). Before touching the contacts, you can make sure you discharge any electrostatic charge by deliberately touching a heating or water pipe (conductive, grounded material). Dirt deposits and oxidation on the contacts can be avoided by storing your camera in a dry location with the lens cap attached and all covers in place.
- Use only accessories specified for this model to prevent faults, short circuits or electric shock.
- Do not attempt to remove parts of the housing (covers) yourself. Repairs must be done at authorized service centers only.
- Protect the camera against contact with insect sprays and other aggressive chemicals. Petroleum spirit, thinner and alcohol must not be used for cleaning. Some chemicals and liquids can damage the camera housing or the surface finish.
- Rubber and plastics are known to expel aggressive chemicals and should therefore not be kept in contact with the camera for extended periods of time.
- Prevent any sand or dust or water penetration into the camera, e.g. during snowfall or rain or on the beach. Be extra careful when changing the lens and inserting or removing the memory card and battery. Sand and dust can damage the camera, the lens, the memory card and the battery. Moisture can cause malfunctions and irreparable damage to the camera and memory card.

LENS

- A camera lens can have the effect of a magnifying glass when exposed to direct frontal sunlight. The camera must therefore be protected against extended exposure to direct sunlight. Using the lens cap and keeping the camera in the shade (ideally in its camera case) will help prevent damage to the interior of the camera.

RECHARGEABLE BATTERY

- Improper use of the batteries or the use of unapproved battery types may result in an explosion!
- Do not expose the rechargeable battery to sunlight, heat, humidity or moisture for prolonged periods of time. Likewise, the batteries must not be placed in a microwave oven or a high-pressure container as this would pose a fire or explosion hazard.
- Do not under any circumstances charge or insert a damp or wet battery!
- A safety valve in the battery ensures that any excess pressure caused by improper handling is discharged safely. It is nevertheless important to dispose of a bloated battery immediately. This battery will pose an explosion hazard!
- Keep the battery contacts clean and easily accessible. Although lithium-ion batteries are secured against short circuits, they should still be protected against contact with metal objects like paper clips or jewelry. A short-circuited battery can get very hot and cause severe burns.
- When a battery is accidentally dropped, make sure to check the housing and the contacts immediately for any damage. A damaged battery can damage the camera.
- In case of noise, discoloration, deformation, overheating or leaking fluid, the battery must be removed from the camera or charger immediately and replaced. Continued use of the battery

may result in overheating, which can cause fire and/or explosion!

- Never throw batteries into a fire as they might explode!
- Keep the battery away from sources of heat in case of a leak or if you smell burning. Leaked fluid can catch fire!
- The use of other chargers not approved by Leica Camera AG can cause damage to the batteries and, in extreme cases, may cause serious or life-threatening injuries.
- Connect the charger to a freely accessible power socket.
- The car charging cable supplied must never be connected while the charger is connected to the mains.
- Battery and charger must not be opened. Repairs must only be carried out by authorized service centers.
- Keep batteries out of the reach of children. Batteries can cause suffocation when swallowed.

FIRST AID

- Battery fluid may cause blindness if it comes into contact with the eyes. Rinse the eyes thoroughly with clean water immediately. Avoid rubbing. Seek medical attention immediately.
- Leaked battery fluid poses an injury hazard when it comes in contact with clothing or skin. Rinse the affected areas thoroughly with clean water.

CHARGER

- Using the charger in the vicinity of broadcasting receivers may interfere with the reception of the device. Ensure a distance of at least 1 m (3 ft) between the charger and the receiver.
- When the charger is in use, it may emit a buzzing sound – this is normal and not a malfunction.
- Disconnect the charger from the mains when it is not in use, because it consumes some (a very small amount) electricity, even when no battery is inserted.
- Always keep the charger contacts clean, and never short circuit them.
- The car charging cable supplied must only be operated in 12V in-car grids and must never be connected while the charger is connected to mains electricity.

MEMORY CARD

- Never remove the memory card during a datasave or card reading process. The camera must not be switched off or be subjected to impact or vibrations while working.
- Do not open the cover/remove the memory card or the battery while the status LED is lit, which indicates memory access. Data on the card may otherwise be destroyed and camera malfunctions may occur.
- Do not drop or bend memory cards as this will cause damage and result in the loss of the stored data.
- Do not touch the connections on the reverse of the memory card and keep them clean and dry.
- Keep memory cards out of the reach of children. Swallowing a memory card may cause suffocation.

SENSOR

Cosmic radiation (e.g. during flights) may cause pixel defects.

CARRY STRAP

- Carry straps are usually made of very robust material. You should therefore keep it out of the reach of children. A carry strap is not a toy and poses a strangulation risk.
- Use the carry straps only for their intended purpose on a camera or on binoculars. Any other use poses the risk of injury and may possibly result in damage to the carry strap and is therefore not permitted.
- Carry straps should also not be used for cameras/binoculars during sports activities with a high risk of getting entangled in the carry strap (e.g. mountain climbing and similar outdoor activities).

Please read the section about “Care/Maintenance” for more information about what to do in case of problems.

GENERAL NOTES

CAMERA/LENS

- Make a note of the serial numbers of your camera (engraved in the base of the camera housing) and lenses, as this information will be extremely important in case of loss.
- Make sure to always have a lens or the camera bayonet cover attached to prevent dust or other foreign bodies penetrating the camera.
- That is why you should always replace lenses quickly and in a dust-free environment.
- Never store the camera bayonet cover or the rear lens cover in a pants pocket, as they will attract lint and dust, which could then be accidentally introduced into the camera.
- Leica releases firmware updates for lenses at irregular intervals. You can download any new firmware version from our homepage and transfer it to your lens. Please read the section “Installing firmware updates” (p. 100) for more information.

LCD PANEL

- Condensation may form on the display if the camera is exposed to great temperature fluctuations. Wipe the screen carefully with a soft, dry cloth.
- The screen image will initially be slightly darker than normal if the camera is very cold when it is switched on. The normal level of brightness will be reached as soon as the display warms up.

RECHARGEABLE BATTERY

- The battery must have a temperature between + 10°C and + 30°C for charging, as the charger will otherwise not switch on or will switch off again.
- Lithium-ion batteries can be charged at any time, regardless of their current charge level. A partially charged battery will charge to full capacity faster than a fully discharged one.
- The rechargeable batteries come only partly charged ex works and should therefore be charged fully before their first use.
- A new battery only reaches its full capacity after it has been fully charged and – by using it in the camera – depleted 2 to 3 times. This depletion process should be repeated roughly every 25 cycles.
- Both battery and charger heat up during the charging process. That is normal and not a malfunction.
- Rapid flashing of the two LEDs (> 2 Hz) when charging commences indicates a charging error (e.g. maximum charging time exceeded, voltages or temperatures outside the permitted ranges, or short circuit). Disconnect the charger from the mains and remove the battery. Ensure that the above temperature conditions are met and then restart the charging process. Please contact your dealer, the Leica office in your country or Leica Camera AG if the problem persists.
- Rechargeable lithium-ion batteries generate power by way of internal chemical reactions. These reactions are influenced by ambient temperature and humidity. To ensure a maximum service life of the battery, it should not be exposed to extreme temperatures (high or low) for extended periods of time (e.g. in a parked car in the summer or winter).
- However, every battery has a limited service life! After several hundred charging cycles, this limitation will become evident as the operating times get significantly shorter.

- The replaceable battery provides power to a back-up battery which is permanently fitted in the camera. This back-up battery retains the set date and time for up to 2 months. Once the back-up battery is depleted, it must be replenished by inserting a charged main battery. The back-up battery will recover its full capacity after approx. 60 hours with the rechargeable battery in place. This process does not require the camera to be turned on. You will, however, have to set the time and date again.
- As the battery capacity deteriorates or if using an older battery, warning messages may appear and some functions may be restricted or blocked entirely.
- Remove the battery if the camera will not be used for an extended period of time. Make sure to switch the camera off via the main switch before removing the battery. Leaving the battery in the camera will result in a deep discharge after a few weeks. Voltage levels will decrease significantly, as the camera uses a low idle current to maintain settings.
- Dispose of damaged batteries in accordance with the relevant regulations at an approved collection point for proper recycling.
- You will find the date of manufacture on the battery itself. The date format is week/year.

MEMORY CARD

- The range of available SD/SDHC/SDXC cards on the market is too extensive for Leica Camera AG to test all types for compatibility and quality. Generally, any type of memory card may be used without any damage to the camera or memory card. As some "no name" cards may not fully comply with the SD/SDHC/SDXC standards, Leica Camera AG cannot provide any guarantee of function.
- We recommend formatting memory cards from time to time, because fragmented residual data from deleted files may block some of the storage capacity.
- Generally, it is not necessary to format (initialize) memory cards that have been previously used. Formatting will, however, be necessary if you insert an unformatted memory card or a card that was formatted in another device (e.g. a computer) for the first time.
- We recommend backing up your data on a PC, because electromagnetic fields, static electricity and any memory card or camera defects could result in permanent damage or loss of your data.
- SD, SDHC, and SDXC memory cards come with a write protection slider to prevent accidental overwriting. This slider is located on the non-beveled side of the card. All data on the card is protected when the slider is set to its lower position, marked LOCK.

SENSOR

- Any dust or dirt particles stuck to the glass cover of the sensor may result in noticeable dark spots or specks on the pictures.

DATA

- All data, including personal information, may be changed or deleted due to incorrect or accidental operation, static discharge, accidents, malfunctions, repairs and other measures.
- Please note that Leica Camera AG will not accept liability for direct or consequential damage due to the manipulation or destruction of data and personal information.

FIRMWARE UPDATE

Leica is continuously working on the further development and optimization of Leica M10-P. As digital cameras have many functions that are controlled electronically, improvements and enhancements to the functions can be installed on the camera at a later date. Leica releases what are known as firmware updates at irregular intervals. Cameras are always supplied from the factory with the latest firmware. Otherwise you can download it from our website yourself and transfer it to your camera.

If you register as an owner on the Leica Camera home page, you will receive a newsletter informing you when a new firmware update is available.

Further information on registration and on firmware updates for your Leica M10-P and on any changes or additions to the details in this manual can be found on our website under "Customer Service" at:

<https://owners.leica-camera.com>

Select menu item "Firmware" to check whether your camera and lenses are running the latest firmware version.

Definition of remarks in this manual

Note

Additional information

Important

Failure to observe the instructions may result in damage to the camera, the accessories or the pictures.

Attention

Failure to observe this information can result in personal injury

TABLE OF CONTENT

FOREWORD	2	PART DESIGNATIONS	20
SCOPE OF DELIVERY	2	CAMERA	20
REPLACEMENT PARTS/ACCESSORIES	3	LENS	22
LEGAL NOTES	4	DISPLAYS	23
LEGAL NOTES	4	VIEWFINDER	23
REGULATORY INFORMATION	4	LCD PANEL	24
DISPOSAL OF ELECTRIC AND ELECTRONIC EQUIPMENT	5	WHEN TAKING A PICTURE	24
IMPORTANT NOTES REGARDING THE USE OF GPS	6	REVIEW MODE	25
IMPORTANT NOTES REGARDING THE USE OF WLAN	7	PREPARATIONS	26
SAFETY REMARKS	8	ATTACHING THE CARRYING STRAP	26
GENERAL INFORMATION	8	PREPARING THE CHARGER	26
LENS	9	CHARGING THE BATTERY	27
RECHARGEABLE BATTERY	9	INSERTING THE BATTERY IN THE CHARGER	27
FIRST AID	9	CHARGE STATUS DISPLAYS ON THE CHARGER UNIT	27
CHARGER	10	INSERTING/REMOVING THE BATTERY	28
MEMORY CARD	10	CHARGE STATUS INDICATOR ON THE LCD PANEL	29
SENSOR	10	MEMORY CARD INSERTION/REMOVAL	30
CARRY STRAP	11	COMPATIBLE LENSES	31
GENERAL NOTES	12	LEICA M LENSES	31
CAMERA/LENS	12	COMPATIBLE LEICA LENSES WITH ADAPTER	31
LCD PANEL	12	LENSES WITH LIMITED COMPATIBILITY	32
RECHARGEABLE BATTERY	12	USABLE, BUT WITH RISK OF DAMAGE TO THE CAMERA AND/OR LENS	32
MEMORY CARD	13	COMPATIBLE, BUT EXACT FOCUSING IS LIMITED	32
SENSOR	14	USABLE, BUT EXPOSURE METERING IS POSSIBLE ONLY IN LIVE VIEW MODE ..	32
DATA	14	INCOMPATIBLE LENSES	32
FIRMWARE UPDATE	14	ATTACHING/DETACHING THE LENS	33

CAMERA OPERATION	34	BASIC PICTURE SETTINGS	50
OPERATING ELEMENTS	34	FILE FORMAT	50
MAIN SWITCH	34	IMAGE PROPERTIES	50
SHUTTER BUTTON	35	JPG RESOLUTION	50
SHUTTER SPEED SETTING WHEEL.....	36	JPG SETTINGS	50
ISO SETTING WHEEL.....	36	LENS DETECTION	52
THUMBWHEEL	37	USING A LEICA M LENS	
DIRECTIONAL PAD/CENTER BUTTON.....	37	WITH 6-BIT ENCODING	52
LV BUTTON/PLAY BUTTON/MENU BUTTON	38	USING A LEICA M LENS	
TOUCH SCREEN	38	WITHOUT 6-BIT ENCODING.....	52
MENU CONTROL	39	USING A LEICA R LENS.....	53
CONTROL ELEMENTS	39	PICTURE MODE	54
STRUCTURE OF THE MENU SCREEN	40	IMAGE TYPES	54
DISPLAY MENU PAGES.....	41	USING THE RANGEFINDER.....	54
MENU NAVIGATION	42	LIVE VIEW MODE	56
FAVORITES MENU	44	FOCUSING	56
DIRECT ACCESS TO MENU FUNCTION	44	DISTANCE METERING METHODS USING THE	
CAMERA DEFAULT SETTINGS	46	RANGEFINDER	56
MENU LANGUAGE	46	DISTANCE METERING METHODS	
DATE/TIME	46	IN LIVE VIEW MODE.....	57
DATE	46	ASSIST FUNCTIONS FOR MANUAL FOCUSING	
TIME.....	46	IN LIVE VIEW MODE.....	58
AUTOMATIC TIME VIA GPS	46	ISO SENSITIVITY	60
TIME ZONE	47	WHITE BALANCE	62
DAYLIGHT SAVING TIME	47	AUTOMATIC/FIXED SETTINGS	62
AUTO POWER SAVING (STANDBY MODE)	47	MANUAL SETTING AFTER MEASUREMENT  Greycard	62
DISPLAY/VIEWFINDER SETTINGS	48	DIRECT SETTING OF THE COLOR TEMPERATURE.....	63
LCD PANEL SETTINGS.....	48	EXPOSURE	64
BRIGHTNESS	48	EXPOSURE METERING METHODS.....	64
INFORMATION DISPLAYS	49	EXPOSURE SETTING	66
		EXPOSURE CONTROL/FUNCTIONS WITH AUTOMATIC EXPOSURE	67

OTHER FUNCTIONS	73	DATA STRUCTURE ON THE MEMORY CARD.....	94
AUXILIARY DISPLAYS.....	73	CHANGING FILE NAMES.....	95
SERIAL EXPOSURES.....	75	CREATING A NEW FOLDER.....	95
INTERVAL SHOOTING.....	75	RESETTING IMAGE NUMBERING.....	96
SELF-TIMER.....	77	COPYRIGHT MARK.....	96
FLASH PHOTOGRAPHY	77	RECORDING THE PICTURE LOCATION WITH GPS.....	97
COMPATIBLE FLASH UNITS.....	77	FORMATTING A MEMORY CARD.....	97
ATTACHING THE FLASH UNIT.....	78	DATA TRANSFER	98
FLASH EXPOSURE METERING (TTL METERING).....	78	WORKING WITH RAW DATA (DNG)	98
FLASH MODES.....	79	RESETTING THE CAMERA	
FLASH CONTROL.....	80	TO FACTORY SETTINGS	99
FLASH EXPOSURE COMPENSATION.....	82	FIRMWARE UPDATE	99
FLASH EXPOSURE DISPLAYS IN THE VIEWFINDER (SYSTEM-COMPATIBLE FLASH UNITS).....	83	REMOTE CAMERA CONTROL (WLAN)	100
PLAYBACK/REVIEW MODE	84	CONNECTION METHOD.....	100
PICTURE REVIEW	84	CREATE PERSONAL PASSWORD.....	101
AUTOMATIC REVIEW OF THE MOST RECENT PICTURE TAKEN.....	84	CHANGE DEVICE NAME (SSID).....	101
DISPLAYS IN PLAYBACK/REVIEW MODE	85	CARE/STORAGE	102
SELECTING/SCROLLING THROUGH PICTURES	86	CAMERA HOUSING	102
ENLARGED CROPPED SECTION	86	LENS	102
DISPLAYING SEVERAL PICTURES AT ONCE	88	LCD PANEL	103
PICTURE MARKING/UNMARKING	89	RECHARGEABLE BATTERY	103
MARKING A PICTURE.....	89	MEMORY CARDS	103
PICTURE UNMARKING.....	90	SENSOR	104
DELETING A PICTURE	90	DUST DETECTION.....	104
DELETING INDIVIDUAL PICTURES.....	91	SENSOR CLEANING.....	104
DELETING MULTIPLE/ALL PICTURES.....	91	FAQ	106
OTHER FUNCTIONS	92	KEYWORD INDEX	108
USER PROFILES	92	MENU OVERVIEW	110
SAVE CURRENT SETTING AS USER PROFILE.....	92	TECHNICAL DATA	112
APPLY/ACTIVATE PROFILE.....	93	LEICA CUSTOMER CARE	116
EXPORTING/IMPORTING PROFILES TO/FROM THE MEMORY CARD.....	93		
DATA MANAGEMENT	94		

PART DESIGNATIONS

CAMERA

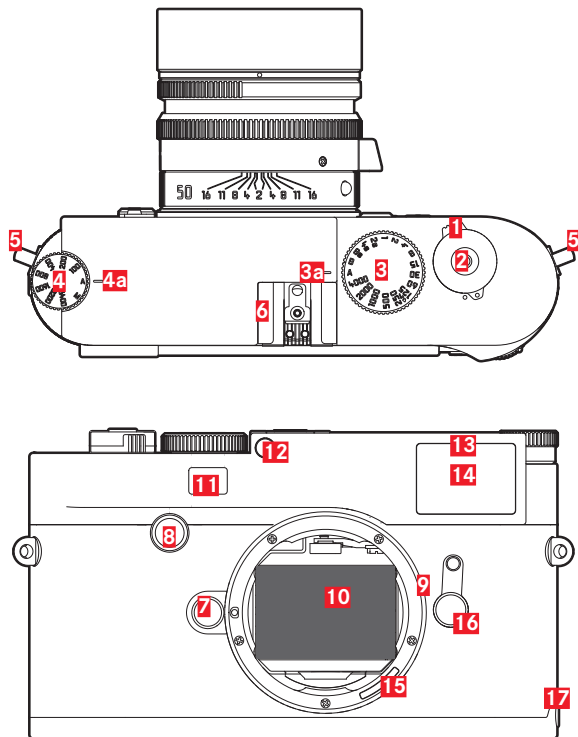

Top view

- 1** Main switch
- 2** Shutter button
- 3** Shutter speed setting wheel
- a** Alignment point for shutter speed setting wheel
- 4** ISO setting wheel
- a** Alignment point for ISO setting wheel
- 5** Carry strap eyelets
- 6** Accessory shoe

Front view

- 7** Lens release button
- 8** Focus button
- 9** Bayonet
- 10** Sensor
- 11** Rangefinder viewing window
- 12** Brightness sensor¹
- 13** Self-timer LED
- 14** Viewfinder viewing window
- 15** 6-bit encoding (sensor for lens detection)
- 16** Image field selector
- 17** Bottom cover locking point

¹ Leica M lenses with viewfinder attachment cover the brightness sensor. Please read the sections "Displays (viewfinder)" and "Leica M lenses" for more information about how to work with these and other lenses.

Rear view

- 18** Viewfinder
- 19** Thumbwheel
- 20** Directional pad
- 21** Center button
- 22** LV button
- 23** **PLAY** button
- 24** **MENU** button
- 25** LCD panel
- 26** Brightness sensor for LCD panel
- 27** Picture / Recording / Datasave LED

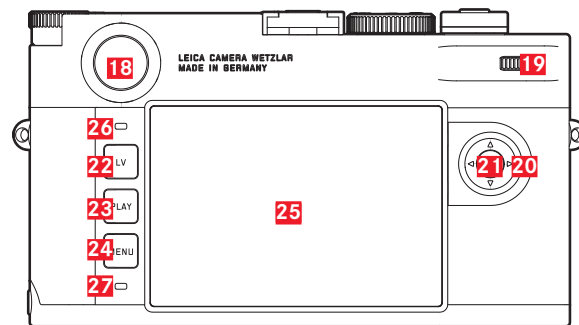
**Bottom view**

(bottom cover fitted)

- 28** Bottom cover
- 29** Locking toggle for bottom cover
- 30** Tripod thread A ¼, DIN 4503 (¼“)

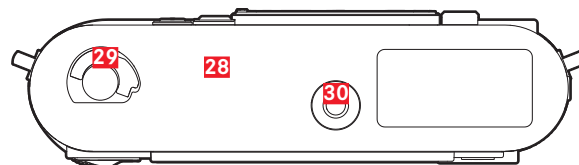

(Bottom cover removed)

- 31** Memory card slot
- 32** Battery compartment
- 33** Battery locking latch
- 34** Latch for bottom cover

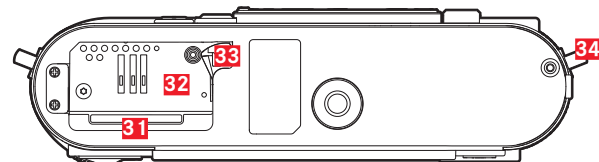

LENS

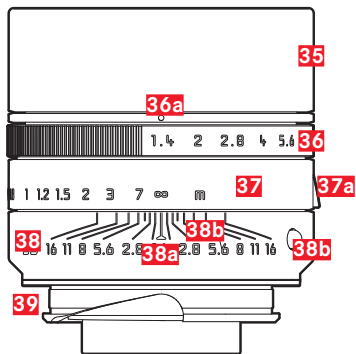

- 35** Lens hood
- 36** Aperture setting ring with scale
 - a** Index for aperture values
- 37** Focus ring
 - a** Focus tab
- 38** Fixed ring
 - a** Focusing Index
 - b** Depth of field scale
 - c** Index button for lens replacement
- 39** 6-bit encoding (sensor for lens detection)

*Representative image. Technical features may vary depending on model.

DISPLAYS

VIEWFINDER

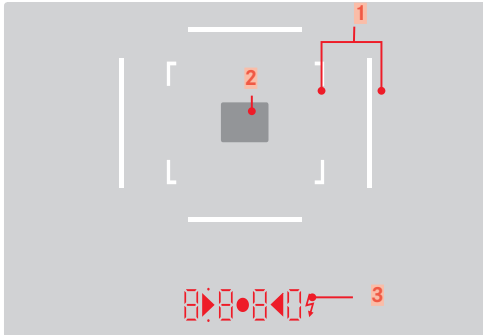

- 3 Digital display
- 8 8 8 0:
 - Displays the automatically calculated shutter speed in aperture priority mode **A** or the countdown of longer shutter speeds in 1 s increments.
 - Warning that the metering or setting ranges are overshot or undershot using aperture priority mode **A**
 - Exposure compensation value (appears for a short time during setting and for about 0.5 s when activating exposure metering by tapping the shutter button)
 - Notification regarding (temporarily) full cache
 - Message: No memory card (**Sd**)
 - Message: Memory card full (**full**)
 - (top):
 - Indicates (when lit) that saved metering values are being used
 - (bottom):
 - Indicates (flashing) that exposure compensation is being used
 - ▶ • ◀:
 - For manual exposure setting:
Concurrently as light balance for exposure compensation. The triangular LEDs give the direction of rotation of the aperture setting ring and shutter speed setting dial to adjust the exposure.
 - Warning before the measuring range is undercut
 - ⚡ Flash symbol:
 - Flash ready to use
 - Details of flash exposure before and after the picture

LCD PANEL

WHEN TAKING A PICTURE

(All displays/values refer to actual settings)

In Live View mode

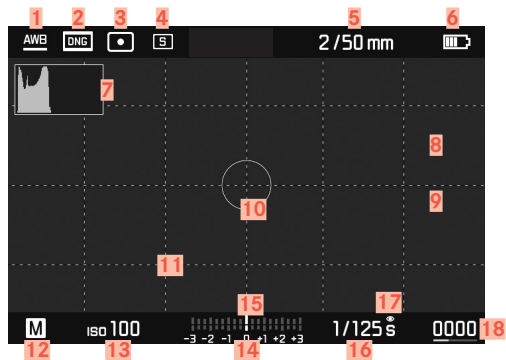

When using the viewfinder

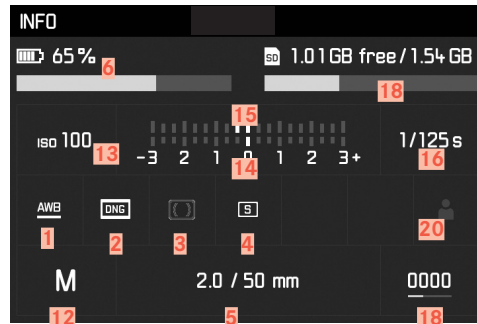

REVIEW MODE

(All displays/values refer to the displayed image)



- 1 White balance mode
- 2 File format/compression level/resolution
- 3 Exposure metering method
- 4 Shutter button/**Drive** mode
- 5 Light intensity/focal length or lens type
- 6 Battery capacity
- 7 Histogram
- 8 Clipping identification of under exposed (blue), or over exposed subject sections (red)
- 9 Identification of in focus edges in the subject (Focus peaking)
- 10 Spot exposure metering field (only if the metering method is switched on)
- 11 Grid lines (choice of 2 variants)
- 12 Exposure mode
- 13 ISO Sensitivity
- 14 Light balance
- 15 Exposure compensation scale
- 16 Shutter speed
- 17 Exposure simulation
- 18 Remaining number of pictures, incl. trend detection by means of bar charts
- 19 Display of cropped section size and position (only visible for enlarged sections)
- 20 User profile
- 21 Remaining memory card capacity
- 22 File number of the picture shown
- 23 Symbol for marked picture

PREPARATIONS

ATTACHING THE CARRYING STRAP

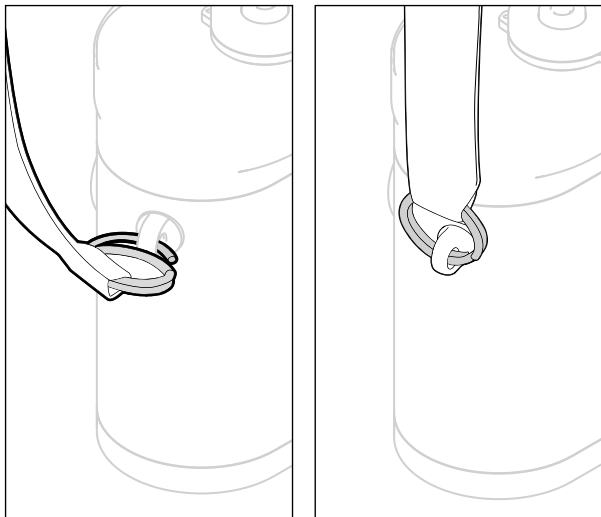

Attention

Once you have attached the carry strap, please make sure that the clips are mounted correctly to prevent the camera from falling.

PREPARING THE CHARGER

Use the mains cable with the matching regional plug to connect the charger to mains electricity.

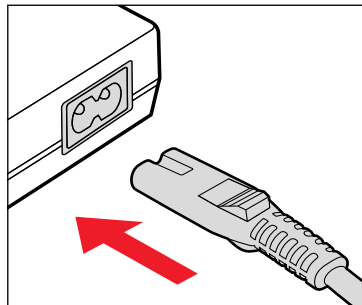

Note

The charger will automatically adapt to local mains voltage.

CHARGING THE BATTERY

The camera is powered by a lithium ion battery.

INSERTING THE BATTERY IN THE CHARGER

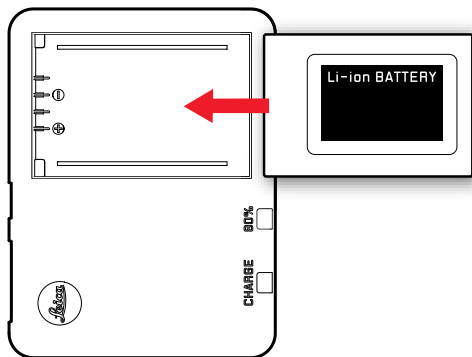

CHARGE STATUS DISPLAYS ON THE CHARGER UNIT

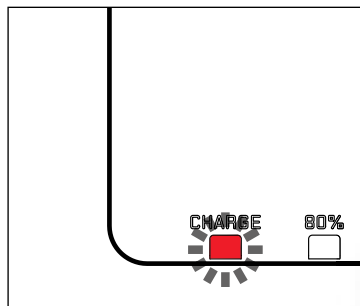

The status LED indicates a correct charging process.

Display	Charge status	Charge time*
CHARGE flashes green	battery is charging	
80% lights up orange	80%	approx. 2 h
CHARGE continuous green light	100%	approx. 3½ h

Disconnect the charger from mains electricity when the charging process is complete. There is no risk of overcharging.

* for a completely discharged battery

INSERTING/REMOVING THE BATTERY

Make sure that the camera is switched OFF (see p. 34)

OPENING THE BOTTOM COVER

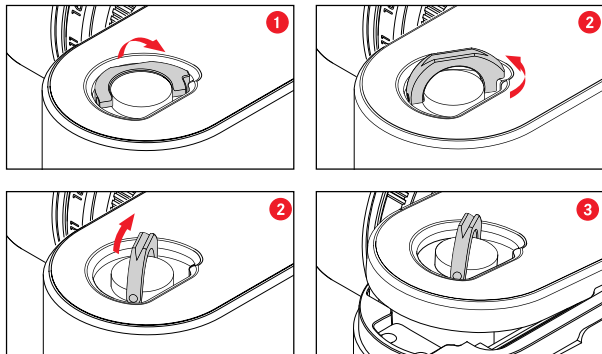

CLOSING THE BOTTOM COVER

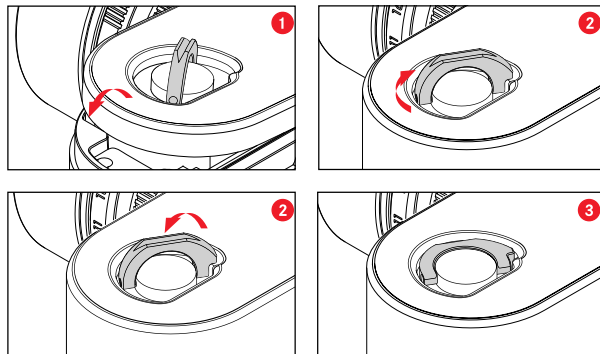

- ▶ Insert the bottom cover (Fig. 1-3)
- ▶ Turn the locking toggle in clockwise direction
- ▶ Click down the locking toggle
- ▶ Check that the bottom cover was inserted and closed correctly

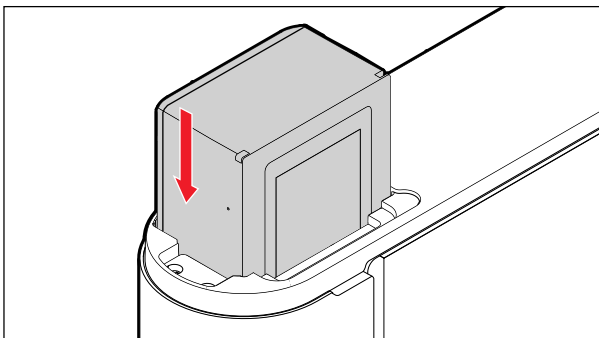
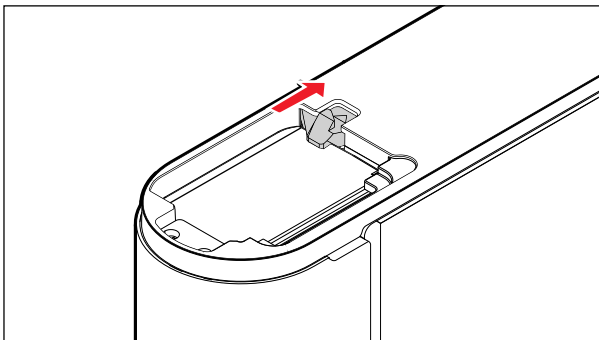
INSERTION**REMOVAL****Important**

Make sure that the bottom cover is securely closed before switching on the camera.

CHARGE STATUS INDICATOR ON THE LCD PANEL

You can see the charge level of the battery on the display if you press the center button.



Display	Charge status
	approx. 88 - 100%
	approx. 63 - 87%
	approx. 47 - 62%
	approx. 36 - 46%
	approx. 26 - 35%
	approx. 0 - 25% Battery needs to be replaced or charged

MEMORY CARD INSERTION/REMOVAL

The camera will save exposures to an SD (Secure Digital), an SDHC (High Capacity) or an SDXC (eXtended Capacity) memory card.

Notes

- SD/SDHC/SDXC memory cards are available from various suppliers in various sizes and with differing read/write speeds. Memory cards with high storage capacities and high read/write speeds offer quick storage and rendering.
- Memory cards with a capacity of less than 1GB are not supported. Memory cards with capacities between 1GB and 2GB must be formatted before first use.
- Make sure the memory card is correctly aligned if you are having difficulties inserting it into the camera.
- Removing the bottom cover or the memory card while the camera is switched on, or switching on the camera while the bottom cover is not attached will trigger the following warning message on the display:
 - Bottom cover open
 - No card available

The memory card slot is located directly next to the battery compartment. Open/Close the bottom cover (see p. 28)

INSERTION

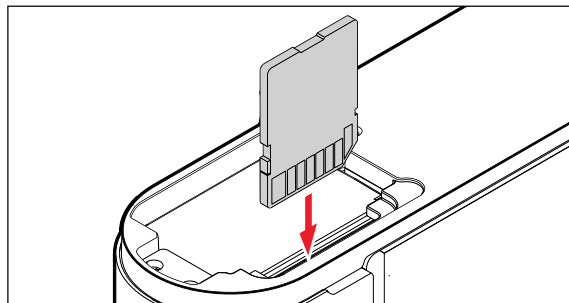

REMOVAL

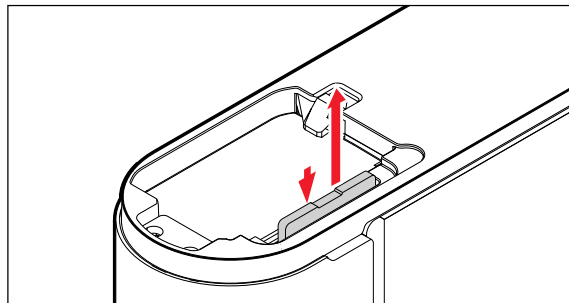

Important

Check that the bottom cover is closed correctly before you switch on the camera.

COMPATIBLE LENSES

LEICA M LENSES

Most Leica M lenses can be used with any lens equipment (with or without 6-bit encoding in the bayonet). Your camera will also deliver great pictures with Leica M lenses without encoding. We recommend entering the lens model type manually to ensure the best possible image quality (see p. 52).

Please read the following sections for details on the very few exceptions and limitations.

Notes

- Our Leica Customer Care department can retrofit many Leica M lenses with 6-bit encoding.
- Leica M lenses come with a control curve that mechanically transfers the set distance to the camera to allow manual focusing via the rangefinder of the Leica M camera. Please note the following when using the rangefinder with wide-aperture lenses (≥ 1.4):
 - The focusing mechanism of every camera and every lens is adjusted individually at the Leica Camera AG factory in Wetzlar with the greatest possible precision. Extremely narrow tolerances are adhered to in this process, which enable precise focusing of every camera/lens combination in photographic practice.

- If wide-aperture lenses (≥ 1.4) are used with an open aperture, the then sometimes resulting very low depth of field and inaccuracies in focusing with the rangefinder may lead to setting errors resulting from the (added) overall tolerance of the camera and lens. It can therefore not be ruled out in such cases that a specific camera/lens combination will manifest systematic deviations.
 - We recommend having the lens and camera checked by Leica Customer Care if you notice a general deviation of the focal position in a specific direction over time. Our technicians will ensure that both products are calibrated within the permissible overall tolerance. However, a 100% match of the focal position cannot be achieved for all pairings of cameras and lenses.
- In such cases we recommend using the Live View function with the appropriate setting facilities.

COMPATIBLE LEICA LENSES WITH ADAPTER

The optional accessory R-adapter M allows the use of Leica-R lenses in addition to Leica M lenses. Please visit the Leica Camera AG website for more information on these accessories.

LENSES WITH LIMITED COMPATIBILITY

USABLE, BUT WITH RISK OF DAMAGE TO THE CAMERA AND/OR LENS

- Lenses with retractable tube must only be used with the tube extended, i.e. never attempt to retract the tube while the lens is attached to the camera. This does not apply for the current Makro-Elmar-M 90 f/4 model, as its tube will not retract into the camera itself and can therefore be used without restriction.
- Heavy lenses attached to a tripod-mounted camera, e.g. Noctilux 50 f/0.95 or Leica R lenses via adapter: Make sure that the tilt of the tripod head cannot move inadvertently when the camera is not held. A sudden tilt and impact could result in damage to the lower edge and the camera bayonet. That is why you should always use the tripod mount on relevantly equipped lenses.

COMPATIBLE, BUT EXACT FOCUSING IS LIMITED

Despite the high precision of the rangefinder on the camera, exact focusing with 135 mm lenses with an open aperture cannot be guaranteed due to the very low depth of field. We therefore recommend stopping down by at least 2 steps. Live View mode, on the other hand, plus the various setting aids provided, allow unrestricted use of this lens.

USABLE, BUT EXPOSURE METERING IS POSSIBLE ONLY IN LIVE VIEW MODE

- Super-Angulon-M 21 f/4
- Super-Angulon-M 21 f/3.4
- Elmarit-M 28 f/2.8 (Serial numbers below 2 314 921)

INCOMPATIBLE LENSES

- Hologon 15 f/8
- Summicron 50 f/2 with close-up
- Elmar 90 f/4 with retractable tube (manufactured 1954-1968)
- Some examples of the Summilux-M 35 f/1.4 (non-aspherical, manufactured 1961-1995, Made in Canada) cannot be attached to the camera or cannot focus to infinity. Leica Customer Care can modify these lenses so that they can be used with the camera.

ATTACHING/DETACHING THE LENS

ATTACHING

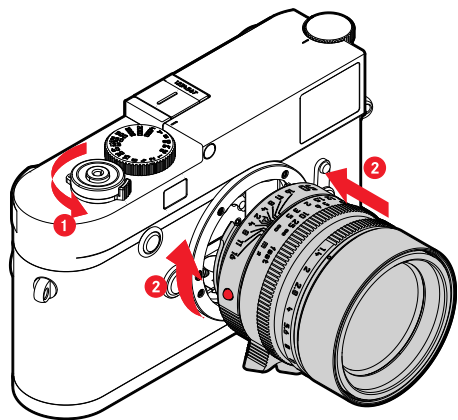

- ▶ Make sure that the camera is switched OFF
- ▶ Hold the lens on the fixed ring
- ▶ Position the alignment button on the lens opposite the release button on the camera housing
- ▶ Attach the lens in this position
- ▶ Turn the lens clockwise until you hear and feel it click into place

REMOVAL

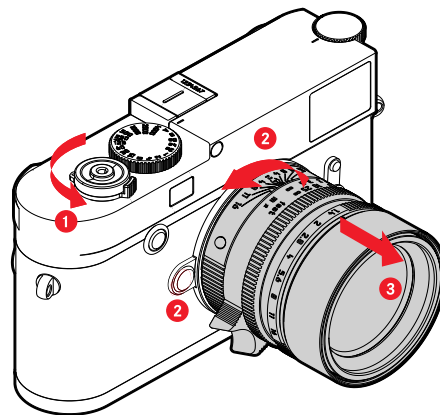

- ▶ Make sure that the camera is switched OFF
- ▶ Hold the lens on the fixed ring
- ▶ Press and hold the release button on the camera housing
- ▶ Turn the lens counter-clockwise until the alignment button is opposite the release button
- ▶ Remove the lens

CAMERA OPERATION

OPERATING ELEMENTS

MAIN SWITCH

The main switch switches the camera on and off.

SWITCHING THE CAMERA ON

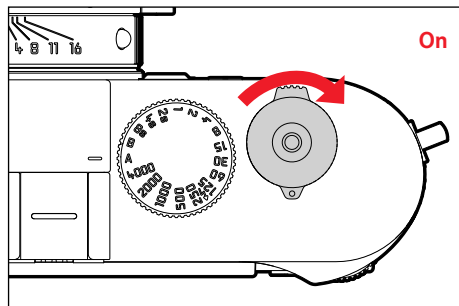

Notes

- Once switched on, the camera will be ready to use after approx. 1 s.
- Once switching on, the LED lights up briefly and the displays in the viewfinder appear.

SWITCHING THE CAMERA OFF

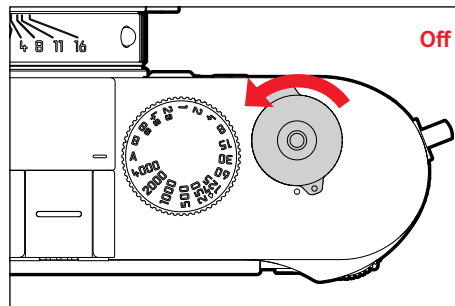

Note

The function **Auto Power Saving** (see p. 47) deactivates the camera automatically if no operation occurs within a preset time. Use the main switch to deactivate the camera if this function is **Off** to prevent inadvertent exposures and battery discharge when the camera is not in use.

SHUTTER BUTTON

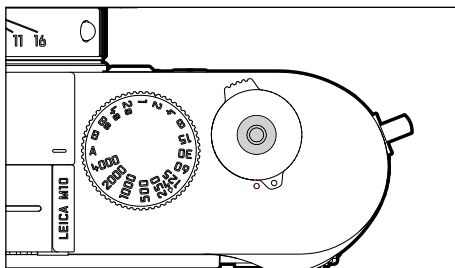

The shutter button works in two stages.

1. **Tap** (= Press the shutter button to the 1st pressure point) saves the metered exposure value in aperture priority mode, i.e. the shutter speed determined by the camera (for more details, refer to the “Metering memory lock” section on p. 68)
 - restarts a self-timer delay in progress
 - reverts the camera to picture mode:
 - if playback mode is set
 - if menu control is active
 - if the camera is in Standby mode
2. **Press down fully**
 - the picture is taken
 - starts a preselected self-timer delay
 - The data is then transferred to the memory card.

Notes

- Press down the shutter button in a smooth motion until you hear the click of the shutter. This will prevent camera shake.
- The shutter button remains locked
 - if the internal buffer memory is (temporarily) full, e.g. after a series of ≥ 16 pictures.
 - if the memory card inserted and the internal buffer memory are (temporarily) full.
 - if the battery has exceeded its performance limits (capacity, temperature, age).
 - if the memory card is write-protected or damaged.
 - if image numbering on the memory card has reached its limit.
 - if the camera prompts for language, date and time settings at first use or after a reset.
 - if the sensor is too hot.
- When the shutter button is released, camera electronics and viewfinder displays remain active for the time set in the main menu for **Auto Power Saving**.

SHUTTER SPEED SETTING WHEEL

The shutter speed setting wheel has no stop, which means it can be turned in either direction from any position. It will click at each engraved position and for intermediate values. Intermediate positions outside the click positions must not be used. Please read the section “Exposure” (see p. 64) for details about exposure settings.

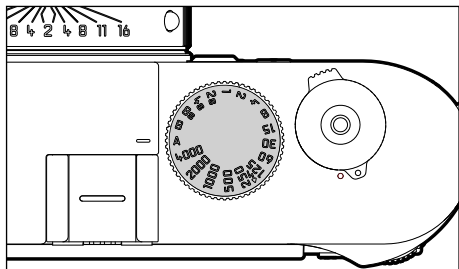

- **A**: Aperture priority mode (automatic shutter speed control)
- **4000 - 8s**: Fixed shutter speed of 1/4000 s to 8 s (with intermediate values, clicking in 1/2 increments)
- **B**: Long-term exposure (bulb)
- **⚡**: The shortest possible sync speed of 1/180 s for flash mode

ISO SETTING WHEEL

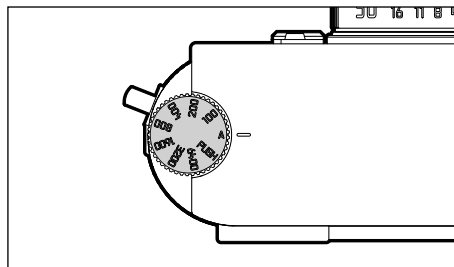

- **A**: Automatic ISO sensitivity control
- **100 - 6400**: Fixed ISO values
- **M**: Manual ISO sensitivity control

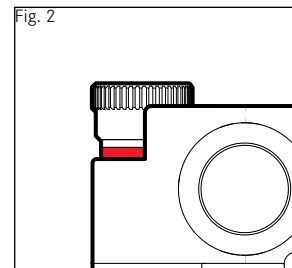
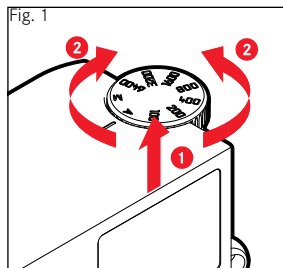

- ▶ Push the ISO setting wheel up until you feel it clicking into place and the red line (fig. 2) is visible
- ▶ Turn the setting wheel to the desired value
- ▶ Push the ISO setting wheel down

THUMBWHEEL

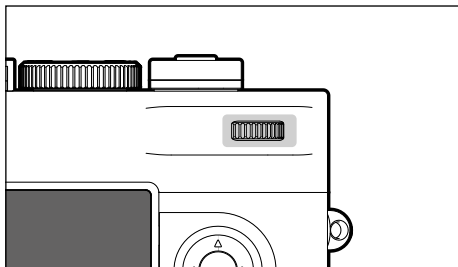

- for menu navigation
- for menu item/function selection
- for exposure compensation value selection
- for enlarging/reducing viewed pictures
- for scrolling through the picture memory

DIRECTIONAL PAD/CENTER BUTTON

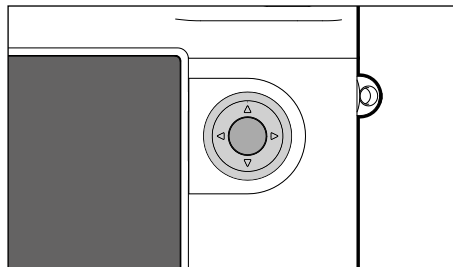

DIRECTIONAL PAD

- for menu navigation
- for menu item/function selection
- for scrolling through the picture memory
- for controlling the selected image section when using  **Greycard**

CENTER BUTTON

- for the status display
- for applying menu settings
- for display of settings/data when taking a picture
- for display of picture data during picture review

LV BUTTON/PLAY BUTTON/MENU BUTTON

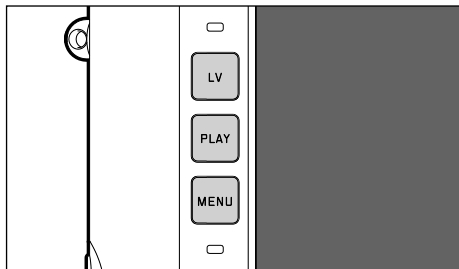

LV BUTTON

- for Live View mode activation/deactivation

PLAY BUTTON

- for (continuous) playback mode activation/deactivation
- for return to full-screen display

MENU BUTTON

- for accessing the **FAVORITES** menu/**MAIN MENU**
- for exiting the **FAVORITES** menu/**MAIN MENU**/submenu

TOUCH SCREEN

GESTURE CONTROL

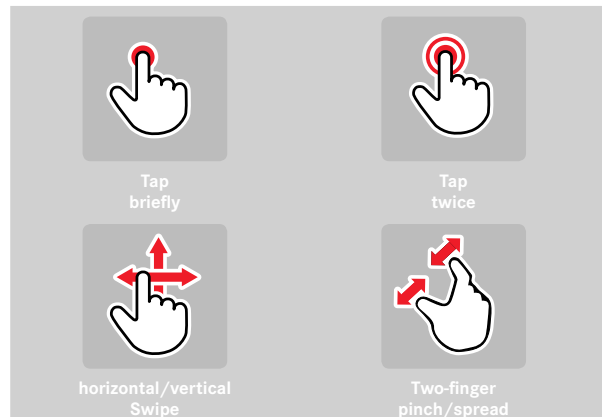

In Picture mode (Live View)

- to select the exposure metering field position (tap the desired on-screen location once)
- to select an image area for viewfinder live zoom (tap twice)

In Playback/Review mode

- to view display information (tap once)
- to scroll through the picture memory (swipe)
- to zoom in/out on viewed pictures (two-finger pinch/spread)

Note

A light touch is enough, do not press down.

MENU CONTROL

Menu sections: **MAIN MENU** and **FAVORITES** menu

MAIN MENU:

- contains all menu items

FAVORITES menu:

- your custom list (see p. 44 for details on how to manage this list)

Note

No favorites menu will be displayed if no menu item is assigned to it.

CONTROL ELEMENTS

The following elements are used for menu control.



18 LV button

19 PLAY button

20 MENU button

15 Thumbwheel

16 Directional pad

17 Center button

STRUCTURE OF THE MENU SCREEN

MAIN MENU

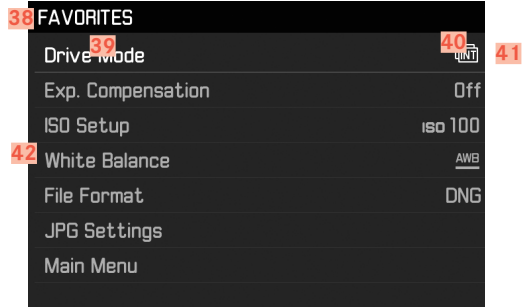

- 38** Menu section: MAIN MENU/FAVORITES
- 39** Name of the menu item
- 40** Setting of the menu item
- 41** Reference to the submenu
- 42** Scrollbar: current position in the menu list

SUBMENU

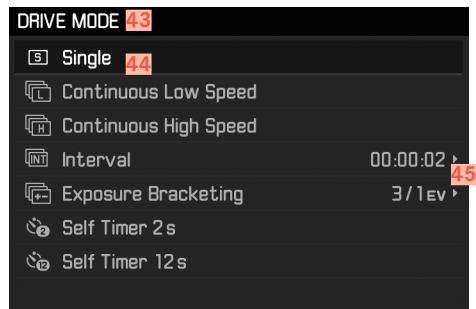

- 43** Current menu item
- 44** Submenu item
- 45** Reference to further submenus

Notes

In some cases, an additional scale will be available, where values can be set or function options can be selected.

DISPLAY MENU PAGES

DISPLAY "HOME" SCREEN (INITIAL MENU CONTROL SCREEN)

In picture mode

if there are no menu items assigned to the favorites menu:

- ▶ Press the **MENU** button 1x
 - **MAIN MENU** appears on screen.

if at least one menu item was assigned to the favorites menu:

- ▶ Press the **MENU** button 1x
 - **The FAVORITES** menu appears.

To get back to the main menu from the favorites menu:

– if the favorites menu consists of one page:

- ▶ Press the **MENU** button 1x

– if the favorites menu consists of 2 pages:

- ▶ Press the **MENU** button 2x

or

- ▶ **Select Main Menu** (last item in the favorites menu)

In Playback/Review mode

- ▶ Tap the shutter button
 - back to picture mode
- ▶ Press the **MENU** button
 - The Home screen is displayed

Display submenu

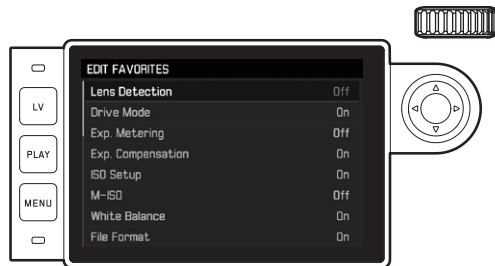

- ▶ Press the center button
or
- ▶ Press the directional pad to the right

MENU NAVIGATION

NAVIGATING WITHIN THE MENU

Page by page navigation

- ▶ Press the **MENU** button

Line by line navigation

- ▶ Turn the thumbwheel
(to the right = down, to the left = up)

or

- ▶ Press the directional pad
 - up/down: Function options selection
 - left/right: Settings within a line or on a scale

Line navigation in submenu items with selectable function variants can also be done via the center button.

Note

- The menu item **Format SD Card** and some submenu items can only be accessed under specific circumstances. Please read the relevant manual sections for more information. The text in the relevant line is displayed in gray to signify the existence of a submenu.

CONFIRM SELECTION

- ▶ Press the center button
 - The screen image changes back to the active menu item. The set function variant is shown on the right in the relevant menu line.

Note

No confirmation is needed for the selection of **On** or **Off**. An automatic save is done.

ONE STEP BACK

- ▶ Press the directional pad to the left
- or
- ▶ Press the **MENU** button 1x

EXIT THE MENU

You can exit the menus and submenus at any time - with/without applying the settings made.

- Go to picture mode:
 - ▶ Press the shutter button
- Go to playback mode:
 - ▶ Press the **PLAY** button

KEYPAD SUBMENU OPERATION

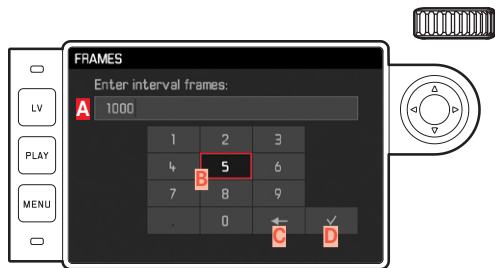

- A** Entry line
- B** Keyboard
- C** “Delete” button (deletion of the respective last value)
- D** “Confirm” button (confirming individual values as well as completed settings; return to the previous menu level without confirming any settings by pressing the **MENU** button)
- E** Shift (toggles upper/lower case)
- F** Changing the character type
- G** Number pad

To move left or right:

- ▶ Press the directional pad right/left

To go up or down:

- ▶ Press the directional pad up/down

To toggle between upper and lower case letters:

- ▶ Use the directional pad to select “Shift” **E**
- ▶ Press the center button

To change the character type (letters/numerals):

- ▶ Use the directional pad to select the **F** key
- ▶ Press the center button

To enter the selected character:

- ▶ Press the center button

To save:

- ▶ Use the directional pad to select the **D** key
- ▶ Press the center button

FAVORITES MENU

Assign you most frequently used menu items to a favorites menu (up to 15 items) for quick and easy access.

MANAGE FAVORITES MENU

Almost all menu items of the main menu are available (for a complete list).

- ▶ Select **Custom Settings** in the main menu
- ▶ Select **Edit Favorites** in the submenu

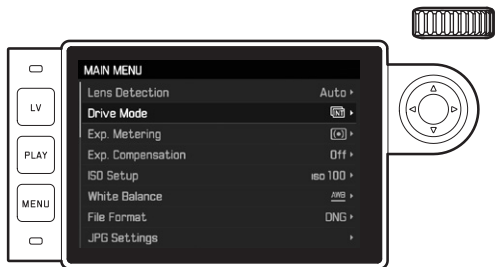

- ▶ Select the desired menu item
- ▶ Select **On** or **Off**.
 - A warning message appears when the favorites menu has reached the maximum of 15 items.

Note

The favorites menu will be deleted completely if all menu items are set to **Off**.

DIRECT ACCESS TO MENU FUNCTION

Assign a menu function to the thumbwheel for extra quick operation: **Exp. Compensation** or **LV Zoom**.

- ▶ Select **Custom Settings** in the main menu
- ▶ Select **Customize Wheel** in the submenu
- ▶ Select **Exp. Compensation/LV Zoom** or **Off**

CAMERA DEFAULT SETTINGS

- The two menu items **Language** and **Date & Time** appear automatically when switching the camera is activated for the first time, when activated after a factory reset (see p. 99) or after a firmware update.

MENU LANGUAGE

Factory setting: English

Available menu languages: German, French, Italian, Spanish, Portuguese, Russian, Japanese, Korean and Traditional or Simplified Chinese

- ▶ Select **Language** in the main menu
- ▶ Select your language
 - Aside from a few exceptions (button names, short names), the language will be changed for all information.

DATE/TIME

DATE

You can choose one of 3 options.

- ▶ Select **Date & Time** in the main menu
- ▶ Select **Date Setting** in the submenu
- ▶ Select the desired date format
(**Day/Month/Year**, **Month/Day/Year**, **Year/Month/Day**)
- ▶ Set the date

TIME

- ▶ Select **Date & Time** in the main menu
- ▶ Select **Time Setting** in the submenu
- ▶ Select the desired display format
(**12 Hours**, **24 Hours**)
- ▶ Set the time
(Select **am** or **pm** for the 12-hour format)

AUTOMATIC TIME VIA GPS

- ▶ Select **GPS** in the main menu
- ▶ Select **ON**
- ▶ Select **Date & Time** in the main menu
- ▶ Select **Auto GPS Time** in the submenu
- ▶ Select **ON**

TIME ZONE

- ▶ Select **Date & Time** in the main menu
- ▶ Select **Time Zone** in the submenu
- ▶ Select your time zone/current location
 - The Greenwich Mean Time offset is shown on the left of the line
 - Major cities in the relevant time zones are shown on the right

DAYLIGHT SAVING TIME

- ▶ Select **Date & Time** in the main menu
- ▶ Select **Daylight Saving Time** in the submenu
- ▶ Select **On** or **Off**.

Notes

- **Auto GPS Time** is available only if the GPS function is set to **ON**.
- **Time Zone** and **Daylight Saving Time** are available only if the GPS function is set to **OFF**.

AUTO POWER SAVING (STANDBY MODE)

The camera will switch to the power-saving standby mode after a preset time to extend battery life if this function is activated.

- ▶ Select **Auto Power Saving** in the main menu
- ▶ Select the desired setting
(**2 Min**, **5 Min**, **10 Min**, **Off**)

Note

The camera can be reactivated from standby mode at any time by pressing the shutter button or by switching the main switch off and on again.

DISPLAY/VIEWFINDER SETTINGS

LCD PANEL SETTINGS

The camera comes equipped with a 3" liquid crystal color screen, which protected by a glass cover made of extremely hard and scratch-resistant Gorilla® glass.

In picture mode and with active Live View function, the screen displays the image captured by the sensor via the attached lens. In review mode, the images saved on the memory card are displayed on the screen. In both cases, the screen shows the entire image field, as well as the selected data and information. When using the rangefinder, you can press the Center button to call up the INFO screen to display a selection of settings (see p. 49).

BRIGHTNESS

RANGEFINDER

The brightness sensor **10** automatically adjusts rangefinder brightness.

Note

This automatic control is not available for Leica M lenses with viewfinder attachments, as they cover the brightness sensor that supplies the required information. The frames and displays will therefore be displayed at a constant brightness when Leica M lenses are used.

LCD PANEL

You can adjust display brightness for best visibility and various lighting conditions.

- ▶ Select **Monitor Brightness** in the main menu
- ▶ Select the automatic setting **(Auto)** or the desired level

INFORMATION DISPLAYS

Various settings appear on the display in picture mode.

When using the rangefinder

- ▶ Press the center button

In Live View mode

Various information is displayed in the header and/or footer line. The image is displayed without information displays in the default setting.

- ▶ Tap the shutter button
 - The footer appears.
- ▶ Press the center button
 - Header and footer are activated permanently. Both lines disappear when you tap the shutter button.

You can select a number of other displays in addition to the standard information contained in the header and footer to adapt the image in picture and review mode to your needs. These include assist functions for exposure settings, image composition and focusing (see p. 56).

BASIC PICTURE SETTINGS

FILE FORMAT

Choose the JPG format **JPG** or the standardized raw data format **DNG** (= digital negative). These can be used individually or simultaneously.

- ▶ Select **File format** in the main menu
- ▶ Select the desired format
(**DNG**, **DNG + JPG**, **JPG**)

Notes

- The standardized DNG (Digital Negative) format is generally used for the storage of raw data.
- The resolution setting for the **JPG** format is used (see next section), i.e. the two files may have differing resolutions if picture data is saved in **DNG** and in **JPG** simultaneously.
- The remaining number of pictures shown in the LCD panel will not necessarily change after every picture taken. A counter change depends on the subject; very fine image structures result in higher data quantities, while homogeneous surfaces mean less data.

IMAGE PROPERTIES

JPG RESOLUTION

The **JPG** format setting offers 3 resolution (number of pixels) options: **L-JPG** (24 MP), **M-JPG** (12 MP) and **S-JPG** (6 MP) (MP = megapixel). You can therefore adjust your settings to the intended use and to the available memory card capacity.

- ▶ Select **JPG Settings** in the main menu
- ▶ Select **JPG Resolution** in the submenu
- ▶ Select the desired resolution

Note

The **DNG** format always uses the highest resolution (24 MP), no matter what **JPG** setting is selected.

JPG SETTINGS

One of the many advantages of digital photography is that it is very easy to change critical properties of a picture.

You can manipulate contrast, sharpness and color saturation before the picture is taken.

Note

The functions and settings described in this section apply to pictures taken in **JPG** format only.

CONTRAST

The contrast setting, i.e. the difference between light and dark image sections, determines whether an image comes across as “flat” or “brilliant”. Increasing or decreasing this difference, meaning that some image sections are rendered with more light or less light, impacts on contrast.

SHARPNESS

Rendering part of the image in complete sharpness, i.e. focusing on the main subject, is prerequisite for a great picture. The impression of sharpness in a picture is largely determined by edge sharpness, i.e. by how small the transition between light/dark is at edges in the picture. Expanding or reducing these areas will therefore change the impression of sharpness.

COLOR SATURATION

The saturation factor in color images determines, whether colors in the picture appear “pale” and pastel-like or “bright” and colorful. While you can’t do anything about weather conditions (clear/misty), you can change the way an image is rendered.

- ▶ Select **JPG Settings** in the main menu
- ▶ Select **Saturation/Sharpness/Contrast** in the submenu
- ▶ Select a level
(**Low**, **Standard**, **High**)

MONOCHROME PHOTOGRAPHY

You can choose to save your images in color or monochrome, provided you take the pictures (also) in JPG format.

- ▶ Select **JPG Settings** in the main menu
- ▶ Select **Monochrome** in the submenu
- ▶ Select **On** or **Off**.
 - The submenu option **Saturation** is not available and appears grayed out if you choose **Monochrome**.

LENS DETECTION

The 6-bit encoding in the bayonet of current model Leica M lenses allows the camera to detect the lens type.

- This information is used for e.g. picture data optimization. Edge darkening, for example, which can become noticeable when wide-angle lenses and large apertures are used, is compensated in the relevant picture data.
- The information provided by the 6-bit encoding is also written to the EXIF data of the pictures. The focal length of the lens is additionally displayed when rendering the extended picture data.
- The camera will write an approximate aperture value to the EXIF picture data, which is calculated individually using the exposure metering system. This is done whether or not an encoded or unencoded lens or a non-M lens is attached via adapter, and also whether or not the lens type was entered in the menu.

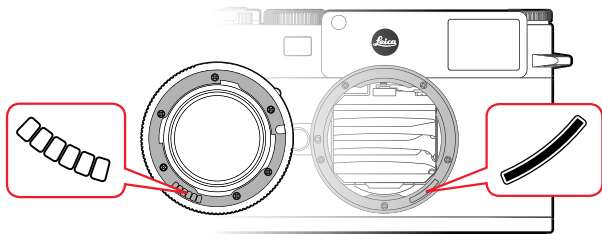

USING A LEICA M LENS WITH 6-BIT ENCODING

The camera will automatically set the correct lens type when a Leica M lens with 6-bit encoding is used. No manual setting will be required. The camera will switch to **Auto** automatically when an encoded Leica M lens is attached, no matter what setting existed originally.

USING A LEICA M LENS WITHOUT 6-BIT ENCODING

The lens type must be entered manually when using a Leica M lens without 6-bit encoding.

- ▶ Select **Lens Detection** in the main menu
- ▶ Select **Manual M**
- ▶ Select the attached lens from the list
 - The lenses are listed with their focal length, apertures and item number.

Notes on Leica M lenses

- Many lenses have their item number engraved on the opposite side of the depth of field scale.
- The list also includes lenses that used to be available without encoding (pre-June 2006). Newer lenses are all provided with encoding and can therefore be automatically detected.
- When using the Leica Tri-Elmar-M 16-18-21 f/4 ASPH., the set focal length is not transferred to the camera housing will therefore also not be included in the EXIF picture dataset. You can, however, enter the focal length manually.
- Tri-Elmar-M 28-35-50 f/4 ASPH., on the other hand, comes equipped with the means for mechanical transmission of the set focal length to the camera need for mirroring the correct bright-line frame in the viewfinder. The focal length is scanned by the camera electronics and the information is used for focal length-specific corrections. Due to space limitations, the menu only contains an item number (11 625). The two other variants (11 890 and 11 894) can, of course, be used as well and the menu settings will apply for them too.

USING A LEICA R LENS

The lens type must also be entered manually when attaching a Leica R lens via the Leica R adapter. The camera will automatically switch to **Manual R** when a Leica R lens is attached, no matter what setting existed originally. You will have to select the lens type from the list.

- ▶ Select **Lens Detection** in the main menu
- ▶ Select **Manual R**
- ▶ Select the attached lens from the list

PICTURE MODE

IMAGE TYPES

USING THE RANGEFINDER

IMAGE FIELD (BRIGHT-LINE FRAME)

The bright-line frame rangefinder of this camera is not just a very high-quality, large, brilliant and bright viewfinder – it also doubles as a highly precise, lens-coupled rangefinder. All Leica M lenses with focal lengths between 16 and 135 mm are coupled automatically when they are attached to a camera. The viewfinder has a magnification factor of 0.73x.

The bright-line frame is coupled with the focusing function in such a way that the parallax – the offset between the lens axis and the viewfinder axis – is compensated automatically. At ranges under 2 m, the sensor captures slightly less than indicated by the inner edges of the bright-line frame, and slightly more at longer ranges (see adjacent diagram). These slight, almost negligible deviations are systemic. The bright-line frame of a camera with viewfinder must be adapted to the view angle of the relevant focal length of the lens. The nominal view angles changes slightly when focusing due to the changing draw-out, i.e. the distance of the lens system to the sensor level. When the set distance is below infinity (and the draw-out accordingly greater), the actual view angle also decreases – the lens captures less of the image object. The view angle differences at greater focal lengths also tend to be larger due to the greater draw-out.

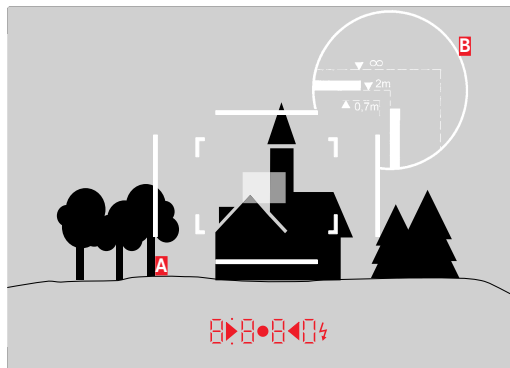

All pictures and bright-light frame positions at 50 mm focal length

A	Bright-line frame
B	Actual image field
Set to 0.7 m	The sensor captures around one frame width less
Set to 2 m	The sensor captures the exact image field shown within the inner edges of the bright-line frame
Set to infinity	The sensor detects around 1 to 4 (vertical or horizontal) frame width(s) more

Notes

- The bright-light frames illuminated by white light LEDs appear alongside the exposure meter LEDs at the lower edge of the viewfinder image, once the camera electronics are activated.
- The rectangular distance measuring field, which is brighter than the surrounding metering field, is in the center of the viewfinder frame. Please read the relevant sections for more information about distance and exposure metering.

The relevant bright-line frame will light up in the combinations 35 mm + 135 mm, 50 mm + 75 mm or 28 mm + 90 mm when lenses with a focal length of 28 (Elmarit as of serial number 2 411 001), 35, 50, 75, 90 and 135 mm are used.

35 mm + 135 mm

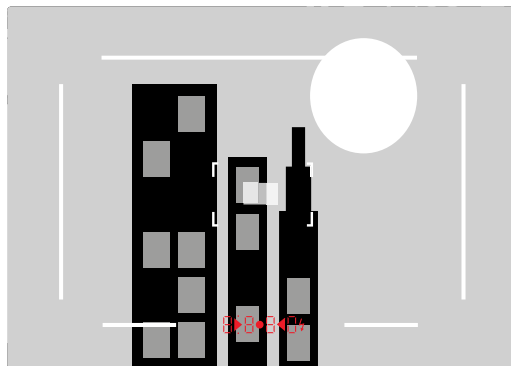

50 mm + 75 mm

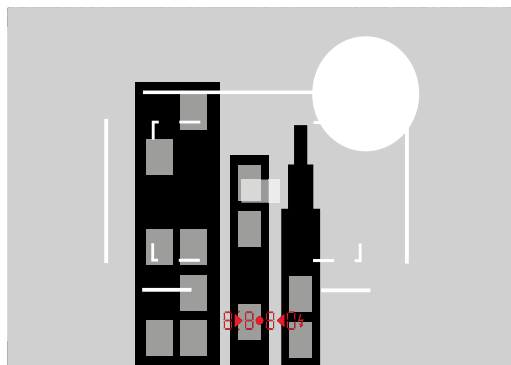

28 mm + 90 mm

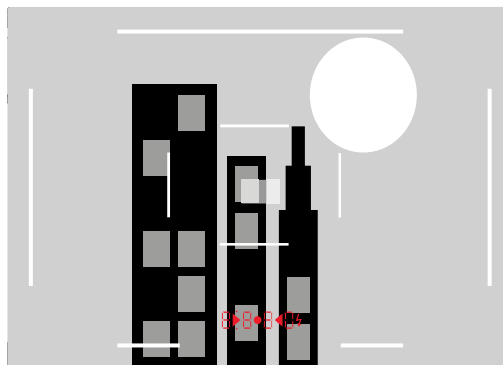

LIVE VIEW MODE

The Live View mode of this camera allows viewing the image object on the display while the picture is taken. The image is shown exactly as it is rendered by the attached lens.

Live View mode ON/OFF

- ▶ Press the **LV** button

Notes

- Live View mode is based on the image captured by the sensor. The camera will then control the shutter. The shutter function is audible and may result in a slight delay in shutter release.
- The camera will warm up when Live View mode is used for an extended period of time. Power consumption will simultaneously increase.
- Alternating current causes brightness fluctuations invisible to the human eye in many light sources. This may result in a flickering of the Live View screen image due to the sensitivity and scan rate of the image sensors. This will not impact on the picture quality. The effect can be avoided by selecting a slower shutter speed.

FOCUSING

Various assist functions are provided for focusing, depending on whether you use the camera's rangefinder or Live View mode.

DISTANCE METERING METHODS USING THE RANGEFINDER

The camera-integrated range finder is very precise due to its great and effective measurement base. Image sharpness can be set according to the superimposed image or the split image method.

SUPERIMPOSED IMAGE METHOD (DOUBLE IMAGE)

For a portrait, you might focus on the eyes using the metering field of the rangefinder and keep turning the focus ring on the lens until the contours are exactly aligned inside the metering field.

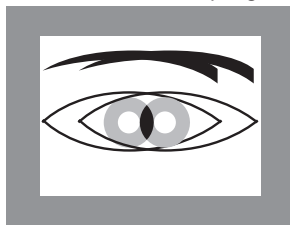

out of focus

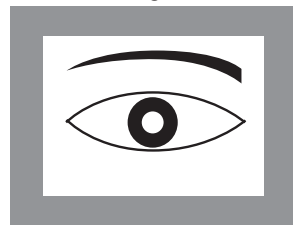

in focus

SPLIT IMAGE METHOD

For an architectural photograph, you might aim the metering field of the rangefinder at e.g. the vertical edge or any other clearly defined vertical line and keep turning the focus ring on the lens until the edge contour or the line is visible at the outer edges of the metering field without any offset.

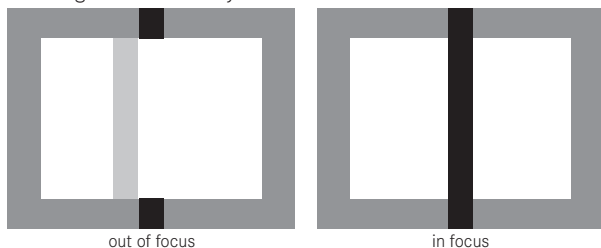

Notes

- Very precise distance measurements are particularly beneficial when using wide-angle lenses with a relatively large depth of field.
- The metering field **2** of the rangefinder is displayed as a bright, sharp-edged rectangle in both methods. The position of the metering field cannot be changed. It will always be at the center of the viewfinder.

DISTANCE METERING METHODS IN LIVE VIEW MODE

You can set the image sharpness in Live View mode via the screen image – it will show the image subject at the exact sharpness as it is rendered by the lens based on the distance and aperture setting. There may be differences between the settings displayed and those perceived to be optimal due to specific sensitivities and functional conditions.

- ▶ Turn the focus ring on the lens to focus on the desired components of the image subject

ASSIST FUNCTIONS FOR MANUAL FOCUSING IN LIVE VIEW MODE

Your camera offers two useful assist functions to facilitate settings and improve setting accuracy:

- The magnification of an (initially) central cropped section of the screen image.
- Marking those section of the screen image that are in focus (Focus Peaking)

The two assist functions can be used simultaneously. Both assist functions are part of the factory settings and therefore activated as standard. You can optionally use only the magnification function or only Focus Peaking – or you can deactivate both.

MAGNIFICATION

Enlarged display of a cropped section:

The larger details of the image subject appear on the screen, the better you can assess their sharpness.

You can access this function with two methods.

Via the focus ring

- ▶ Select **Capture Assistants** in the main menu
- ▶ Select **Focus Aid** in the submenu
- ▶ Select **Automatic**
- ▶ Turn the focus ring to magnify the desired parts of the image subject.
- ▶ Tap and hold the shutter button
- ▶ Turn the focus ring to sharpen the desired parts of the image subject.

Via the thumbwheel

- ▶ Select **Custom Settings** in the main menu
- ▶ Select **Customize Wheel** in the submenu
- ▶ Select **LV Zoom**
- ▶ Turn the thumbwheel to magnify the desired parts of the image subject.
- ▶ Turn the focus ring to sharpen the desired parts of the image subject.

Notes

- The screen image will show the following when the focus ring or the thumbwheel is turned:
 - the enlarged cropped section
 - the approximate position of the cropped section in the overall image at the bottom left (you will see a framed rectangle)
- You can move the cropped section within the image field by pressing the directional pad. Cross hairs in the image field show the center of the shifted cropped section
- Use the thumbwheel to choose one of two magnification factors.
- You can return to the normal, i.e. non-magnified view at any time:
 - By tapping the shutter button
 - By turning the thumbwheel in anti-clockwise direction
- Turning the focus ring on the lens will return the view to the most recently used cropped section size.

FOCUS PEAKING

The contours of objects shown in perfect focus on the LCD panel can be rendered in color for easy recognition. The four colors (red, blue, green, white) that are available enable it to be adjusted to any background.

- ▶ Select **Capture Assistants** in the main menu
- ▶ Select **Focus Peaking** in the submenu
- ▶ Select the desired color or **Off**

Use

- ▶ Select an image section
- ▶ Turn the focus ring to mark the desired image subject components
 - All image components that are rendered in focus with the selected distance setting are marked with a silhouette in the selected color.



Important

- This function relies on focus peaking, i.e. differences between bright and dark. This is why subjects that are not in focus, but that have a high contrast level, may be highlighted.
- The accuracy of the display decreases specifically when a wide-angle lens with a small aperture is used (= high depth of field).

ISO SENSITIVITY

The ISO setting covers a range of ISO 100 - 50000, and thus enables you to adapt to the relevant situation as required.

As well as the fixed settings, the camera also features the **A** function, in which the camera automatically adjusts the sensitivity to the ambient brightness and the shutter speed/aperture settings. In conjunction with aperture priority mode, this function extends the range for automatic exposure control. There is more leeway for the use of preferred shutter speed and aperture combinations when setting the exposure manually. You can set priorities within the scope of the automatic setting, e.g. for reasons of picture composition.

Note

When high ISO values are used or the image is edited later, image noise, as well as vertical and horizontal stripes may become visible, particularly in front of larger, evenly lit areas of the image subject.

Choose a click values engraved on the ISO setting wheel or the positions:

- **A**: for automatic setting; values between ISO 200 and 50000 will be used
- **100 - 6400**: Fixed ISO values
- **M**: for intermediate values, z. B. 250 or for values greater than 6400

WHEN A FIXED ISO VALUE ENGRAVED ON THE ISO SETTING WHEEL IS TO BE SELECTED

- ▶ Turn the ISO setting wheel to a position in which the desired value or setting matches up with the alignment point
 - The set value is displayed:
 - in the viewfinder (for approx. 2 s instead of the shutter speed)
 - in the display (only if the settings were called up beforehand)

WHEN INTERMEDIATE VALUES OR HIGHER VALUES THAN ISO 6400 ARE TO BE SET

- ▶ Select **ISO Settings** in the main menu
- ▶ Select **M-ISO** in the submenu
- ▶ Select the desired value

TO RESTRICT THE AUTOMATIC SETTING RANGE

- ▶ Select **ISO Settings** in the main menu
- ▶ Select **Maximum Auto ISO**, or **Maximum Exposure Time** in the sub-menu
- ▶ Select the desired value

You define the area within which the automatic setting should be applied in the submenu **Maximum Auto ISO**, where you select the highest sensitivity value.

You can allow the camera to ensure blur-safe exposure times in the submenu **Maximum Exposure Time** – by choosing one of the three focal length-specific settings **1/f**, **1/(2f)**, **1/(4f)**¹ or you can specify the greatest focal length manually between **1/2s** and **1/500s**. In the focal length-specific settings, the camera will only switch to a higher sensitivity if the shutter speed would fall below the set threshold due to low light; for example with a 50 mm lens at speeds slower than 1/60s at **1/f**, 1/125s at **1/(2f)** or 1/250s at **1/(4f)**.







¹ This function requires the use of encoded lenses or the setting of the lens type used in the menu.

WHITE BALANCE

In digital photography, white balance ensures neutral color rendering in any light. White balance is based on the camera being preset to render a particular light color as white.

Four methods are provided: automatic control, fixed presets, manual setting via measurements or a direct setting of the color temperature.

AUTOMATIC/FIXED SETTINGS



- **Auto**: for automatic control, which delivers neutral results in most situations,
- Six fixed presets for most frequently encountered light sources:
 -  **Daylight**: for outdoor pictures in sunlight
 -  **Cloudy**: for outdoor pictures in cloudy conditions
 -  **Shadow**: for outdoor pictures with the main subject in shadow
 -  **Tungsten**: for indoor pictures with (predominantly) incandescent lamp light
 -  **Fluorescent Warm**: for indoor shoots using (predominantly) warm light from fluorescent tubes, for example in living quarters with warm light similar to incandescent light at approx. 3700 K¹
 -  **Fluorescent Cool**: for indoor shoots using (predominantly) cool light from fluorescent tubes, e.g. in work environments

▶ **Select White Balance**

▶ Select a setting

MANUAL SETTING AFTER MEASUREMENT **Greycard**

- ▶ Select **White Balance** in the main menu
- ▶ Select  **Greycard** in the submenu
 - A message appears on the display:

Please take a picture for setting the white balance
- ▶ Take the picture
 - Make sure that the image field contains a white or neutral gray (reference) surface.
 - The following will appear on the LCD panel:
 - the image based on **automatic** white balance
 - cross hairs in the center of the image
 - **Preview** at the top right  to prompt further operation
- ▶ Press the relevant side of the directional pad to move the cross hairs onto the subject detail you want to use as basis for the new white balance setting (e.g. the reference surface above).
- ▶ Press the center button
 - The color rendering in the image is adjusted accordingly. **Save** appears at the top right  to prompt further operation

¹ All color temperatures are stated in Kelvin.

To apply the new white balance setting

- ▶ Press the center button again
 - A message appears on the display: `White balance is set`

To repeat the entire process

- ▶ Press the **MENU** button

A value determined via this process will remain set (i.e. it will be used for all further photographs) until you take new measurements or use another saved white balance setting.

DIRECT SETTING OF THE COLOR TEMPERATURE

You can directly set values between 2000 and 13100 K (from 2000 to 5000 K in increments of 100, from 5000 to 8000 K in increments of 200 and from 8000 to 13100 K in increments of 300). That gives you a very wide range to choose from, covering virtually all color temperatures that can occur in real life and within which you can adapt color rendering to any light color and your personal preferences with incredible detail.

- ▶ Select `White Balance` in the main menu
- ▶ Select `Color Temperature` in the submenu
- ▶ Select the desired value

EXPOSURE

EXPOSURE METERING METHODS

SPOT METERING (Spot)

Spot metering only captures and analyzes a small area in the middle of the screen image designated by a circle.

CENTER-WEIGHTED METERING (Center-weighted)

This method considers the entire image field. The image components captured in the center will, however, impact on the calculation of the exposure value more so than areas around the edges.

MULTI-FIELD METERING (Multi Point)

This metering method is based on the detection of multiple values. These values are used in an algorithm to calculate an exposure value appropriate for an appropriate rendering of the assumed main subject.

Depending on whether Live View mode is used, various metering methods are available.

When using the rangefinder

Mostly center-weighted metering.

The light reflected by the light-colored shutter blades is captured and measured by a photodiode. When the metering range of the exposure meter is undercut in a manual setting and very low light density then the triangular LED (▶) in the viewfinder will flash as a warning; analogously the LED on the right (◀) will flash when the metering range of the exposure meter is overshoot. Should a correct exposure not be achievable using the available shutter speeds in aperture priority mode, then the shutter speed icon will flash as a warning. Undercutting or overshooting the required shutter speed (the longest or shortest available) will cause the relevant icon to flash. As exposure metering is done with the working aperture, the same can be achieved by stopping down the lens.

In Live View mode

Either spot, center-weighted and multi-field metering. The metering will then be done via the picture sensor.

The readiness of the exposure meter is signaled by continuously lit displays in the viewfinder or on the screen:

- the shutter speed is displayed in aperture priority mode
- one of the two triangular LEDs lights up in the viewfinder, possibly in conjunction with the round LED in the middle, and the light balance is shown on the screen for a manual setting.
- the line on the left of the light balance will flash in the display if the metering range is undercut/overshot.

When the shutter button is released without activating the shutter, the relevant LED(s) will remain lit until the camera powers down automatically.

The exposure meter is disabled when the shutter speed setting wheel is set to **B**.

- ▶ Select **Exp. Metering** in the main menu
- ▶ Select a metering method
 - The set metering method is displayed in the header of the display image in Live Mode; it appears on the **INFO** screen (see p. S. 49) if the viewfinder is used.

Note

The appropriate shutter speed for correct exposure or the deviation from a correct exposure setting is shown or determined with the help of the viewfinder or screen display.

EXPOSURE SETTING

The camera offers two exposure modes: Aperture priority mode or manual setting. Choose one of the two options depending on image subject, situation or individual preference.

APERTURE PRIORITY MODE A

When the shutter speed setting wheel is in the **A** position, the camera electronics will calculate the correct shutter speed automatically and steplessly in the range between 1/4000 s and 4 min (max. exposure time available only for ISO 100/200). The setting is calculated in accordance with the set sensitivity, metered brightness and the manually selected aperture. The resulting shutter speed is displayed in half increments for more transparency.

The remaining exposure time after shutter release is counted down in seconds on the display for shutter speeds greater than 2 s. The actual calculated and steplessly controlled exposure time may vary from the exposure time displayed in half step increments: if e.g. the display shows **1/6** (the closest value) before shutter release, but the calculated exposure time is longer, then the countdown after shutter release can start from **1/9**. Under extreme lighting conditions and based on all the parameters, the exposure meter may generate a shutter speed that is outside the working range, i.e. brightness values that would require shorter exposures than 1/4000 s or longer than 4 min. If that is the case, then the camera will use the stated min. or max. shutter speeds and these values will flash as a warning in the viewfinder.

Notes

- Image noise becomes apparent when using higher sensitivities, particularly on uniform dark areas. In order to reduce this annoying phenomenon, the camera will take a second “black picture” (taken with the shutter closed) automatically after pictures taken with slow shutter speeds and high ISO values. The noise metered in this parallel picture is then digitally “subtracted” from the data for the actual picture. As a result, the message **Noise reduction** will appear in the display for **12s**¹. The doubling of the “exposure” time must be taken into account for long exposure times. The camera must not be switched off during that time.
- When the **B** function is selected in conjunction with auto shutter release (see S. 77), then the shutter button doesn’t have to be held down and the shutter will remain open until the shutter button is pressed again (the equivalent of a **T** function).

¹ Time display is an example.

MANUAL EXPOSURE SETTING

- ▶ Tap the shutter button
- ▶ Set the desired exposure (using the shutter speed setting wheel or the aperture setting wheel on the lens).
 - In Live View mode this is done with the help of the mark on the light balance in the footer of the screen image.
 - When the rangefinder is used, this is done with the help of a light balance consisting of three LEDs.

As well as the direction of rotation of the shutter speed setting wheel and aperture setting ring necessary for correct exposure, the three LEDs of the light balance also indicate underexposure, overexposure and correct exposure as follows:

- ▶ Underexposure by at least one aperture stop; turn to the right
- ▶● Underexposure by a 1/2 aperture stop; turn to the right
 - Correct exposure
 - ◀ Overexposure by a 1/2 aperture stop; turn to the left
 - ◀ Overexposure by at least one aperture stop; turning to the left is required

Notes

- The shutter speed setting wheel must be clicked to one of the engraved exposure shutter speeds or to one of the intermediate values.
- The remaining exposure time after shutter release is counted down in seconds on the display for shutter speeds greater than 2 s.

EXPOSURE CONTROL/FUNCTIONS WITH AUTOMATIC EXPOSURE

EXPOSURE SIMULATION

You can now assess the effect of the relevant exposure setting on the image before taking the picture. There are two assessment methods available.

- Release button half pressed
- Permanent

With **Release half pressed**, the image object is shown in Live View mode with the brightness matching the optimal exposure setting¹, while the shutter button is tapped and held. This applies irrespective of the exposure mode used (aperture priority/manual setting), and irrespective of the default shutter speed/aperture values. The brightness of the screen image matches the exposure setting. This is displayed as . Conversely, the actual image effect at **Permanent** will also be displayed permanently whatever the exposure mode.

- ▶ Select **Capture Assistants** in the main menu
- ▶ Select **Exposure Simulation** in the submenu
- ▶ Select **Release button half pressed** or **Permanent**

¹ This will apply as long as the subject brightness and the set exposure don't result in excessively low or high brightness values, and as long as the internal exposure setting is not greater than 1/60 s.

METERING MEMORY LOCK

We often want to arrange important image components outside the center of the picture for design reasons and these components may sometimes be very bright or very dark. Center-weighted metering and spot metering, however, mainly capture an area in the center of the image and are calibrated to an average gray scale value.

Image subject or situations like the ones described above can be easily handled in aperture priority mode using the metering memory lock.

Notes

- A metering memory lock doesn't make much sense in conjunction with multi-field metering, because a targeted capture of an individual image component will not be possible.
- In conjunction with exposure lock, Live View also offers an exposure simulation feature (see S. 67).

Aim at the important image component (using the metering field for spot metering) or alternatively at another detail with average brightness.

- ▶ Tap the shutter button
 - The measurement is taken and saved.
 - As long as the shutter button is held at the half-way mark, a small red dot will appear in the viewfinder at the top in the number line for confirmation, and the exposure time won't change, even if the lighting conditions change.
 - Pan the camera to capture the final trim while keeping the shutter button pressed.
- ▶ Shutter release

A change in the aperture setting after the metering memory lock is set will not result in an adjustment of the shutter speed, i.e. the end result would be an incorrect exposure. The metering memory lock is canceled when you remove your finger from the shutter button.

EXPOSURE COMPENSATION

Exposure meters are calibrated for a medium gray scale value (18% reflection), which matches a standard, i.e. average image subject. Should the measured image detail not fulfill that requirement, then the a relevant exposure compensation can be effected.

Specifically where several pictures are taken in sequence, for example if for a series a slightly lesser or greater exposure is desired for a particular reason, then exposure compensation can be a very useful function: In contrast with the metering memory lock, this setting remains active until it is reset.

Exposure compensation can be set in the range $\pm 3\text{EV}$ in $1/3\text{EV}$ increments (EV: exposure value).

Using thumbwheel control

- ▶ Select **Custom Settings** in the main menu
- ▶ Select **Customize Wheel** in the submenu
- ▶ Select **Exposure Compensation**
- ▶ Confirm the setting
- ▶ Set the desired value using the thumbwheel

Using menu control

- ▶ Select **Exposure Compensation** in the main menu
 - A scale appears as a submenu item.
- ▶ Set the desired value

Notes

- In case of **A**, the compensation value is displayed in the viewfinder, for example **1.0- / 0.3** (temporary display instead of the shutter speed). Then the compensation value is shown in the form of changed shutter speeds and a flashing dot at the bottom or for about 0.5 s when the display is activated.
- Regardless of the setting method, the value is displayed in Live View mode and in the INFO screen, represented by a mark in the lower part of the light balance if the viewfinder is used. In the initial menu list, the compensation value is indicated by **EV+X¹**.

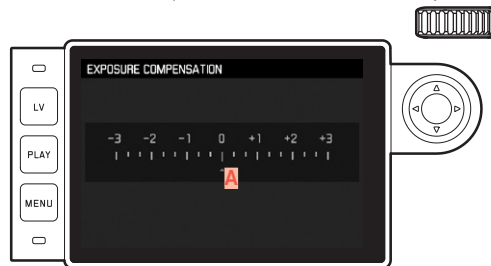

A Set compensation value (marks at 0 = Off)

- Set compensation values remain effective until they are manually reset to 0, i.e. even if the camera is switched off and on again in the meantime.
- They can be reset using either menu control or the thumbwheel.

¹ "X" is a representative placeholder for the relevant value in the positive or negative range.

AUTOMATIC BRACKETING

Many attractive image subjects are rich in contrast, which means they have very bright and very dark areas. The image effect can be dramatically different, depending to which of these you align your exposure. In these cases, the automatic bracketing function in aperture priority mode allows you to produce several alternatives with graduated exposure, i.e. using different shutter speeds. You can then select the picture you like best or use relevant picture editing software to calculate an image with a particularly broad contrast spectrum (HDR).

You can choose from 5 graduations (0.3EV, 0.7EV, 1EV, 2EV, 3EV) and 3 or 5 pictures per series.

- ▶ Select **Drive Mode** in the main menu
- ▶ Select **Exp. Bracketing** in the submenu
- ▶ Select the desired number of pictures in the submenu under **Frames**
- ▶ Select the desired exposure offset in the submenu under **F-Stops**
- ▶ Select the desired **exposure compensation** value in the submenu
 - The marked exposure values change positions according to the settings selected. In the case of exposure compensation, the scale also shifts.
- ▶ All pictures are taken by pressing the shutter button once or several times

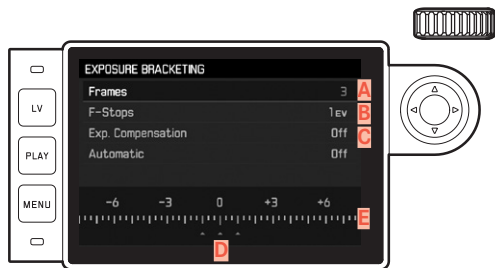

- A** Number of pictures
- B** Exposure difference between the pictures
- C** Exposure compensation setting
- D** Light value scale
- E** Red highlighted exposure values for pictures (the scale will be offset by the relevant value if exposure compensation is set concurrently.)

Notes

- The following rule applies when using automatic bracketing: With automatic ISO sensitivity control (see S. 60) enabled, the sensitivity calculated by the camera automatically for the raw picture will also be applied to all other pictures in a series, i.e. the ISO value will not change during bracketing. This may mean that the slowest shutter speed specified under **Maximum Exposure Time** is exceeded.
- The focus range for automatic bracketing may be limited (depending on the originally set shutter speed). The specified numbers of pictures will be taken regardless. Several pictures in a series may consequently be taken with the same exposure values.
- The function remains active until another function is selected in the **Drive Mode** submenu, or the camera is switched off and on again. If no other function is selected, another series of pictures is taken each time the shutter button is pressed.

LONG-TERM EXPOSURE (B)

In setting **B**, the shutter remains open as long as the shutter button is held down (up to max. 4 min depending on the ISO setting).

This function can also be used to permanently set shutter speeds longer than 8 s:

- ▶ Set the shutter speed setting wheel to **B**
- ▶ Press the center button for approx 1 s
 - The submenu containing the shutter speeds or **B** is shown in the display. Available shutter speeds are indicated in white (may vary depending on ISO sensitivity), those not available appear in gray.
- ▶ Select the desired shutter speed
 - Exit the submenu by tapping the shutter button, pressing the **MENU** button or the center button.
- ▶ Shutter release

An additional T function is available in conjunction with the self-timer: The shutter will open after the preset delay automatically if **B** is set and the self-timer is also activated by tapping the shutter button. It will then remain open – without having to hold down the shutter button – until the shutter button is tapped again. This allows you to prevent any blurring for long exposures when the shutter button is pressed.

In each of these cases, the exposure meter remains deactivated; after shutter release, however, the digital number display in the viewfinder counts the elapsed exposure time in seconds.

Notes

- Long exposure times may cause severe image noise.
- After exposures with slower shutter speeds (from approx. 1/30 s, may differ depending on other menu settings), a data processing procedure will help reduce this annoying phenomenon. The process will take as long as the exposure. The doubling of the “exposure” time must be taken into account for long exposure times. The camera must not be switched off during that time.
- At shutter speeds from 2 s, the message **Noise reduction 12s¹** appears in the display.

¹ Time display is an example.

OTHER FUNCTIONS

AUXILIARY DISPLAYS

HISTOGRAM

Histogram represents the brightness distribution in the picture. The horizontal axis shows the graduated values from black (left) through gray to white (right). The vertical axis corresponds to the number of pixels at each brightness level.

This form of representation – in conjunction with the impression of the actual image – allows an additional quick and easy assessment of the exposure setting.

- ▶ Select **Capture Assistants** in the main menu
- ▶ Select **Histogram** in the submenu
- ▶ Function activation (**On**) or deactivation (**Off**)

Notes

- The histogram will only appear when the shutter button is tapped if the function **Exposure Simulation** is set to **Release button half pressed** (see p. 67).
- The histogram is always based on the brightness displayed, i.e. depending on the settings used, it may not represent the final exposure.
- In picture mode, the histogram should be regarded as a "trend indicator" and not as a depiction of the exact numbers of pixels.
- The histograms when reviewing and taking a picture may differ slightly from one another.
- The histogram function is not available for the simultaneous playback of multiple thumbnails or enlarged pictures.

GRID LINES

The grid divides the image frame into nine equal fields. It helps with e.g. picture composition and camera orientation. You can choose one of two grid displays. They divide the frame into 3 x 3 or 6 x 4 fields.

- ▶ Select **Capture Assistants** in the main menu
- ▶ Select **Grids** in the submenu
- ▶ Select the desired grid type (**3x3**, **6x4**) or deactivate the function (**Off**)

CLIPPING

The Clipping display marks bright or dark areas in the image lacking definition (bright areas flash in red; dark areas flash in blue). To adjust these displays to specific conditions or your compositional ideas, you can specify limit values, i.e. the level of over/underexposure at which they appear. The Clipping display therefore offers a very simple and exact means for checking and adjusting your exposure settings.

- ▶ Select **Capture Assistants** in the main menu
- ▶ Select **Exposure Clipping** in the submenu
- ▶ Activate the function (**On**) or deactivate it (**Off**) in the submenu **Clipping Enabled**
 - The two other lines are not selectable (= gray) when the function is deactivated.
- ▶ Optional: Set the desired lower and upper threshold values in the **Lower threshold value** and **Upper threshold value** lines.

Note

The clipping display always refers to the currently displayed cropped section.

SERIAL EXPOSURES

The camera is set to single shot exposures by default. You can also take serial exposures to e.g. capture motion sequences at various stages. Use menu control to decide whether you want to take single shots or serial exposures.

- ▶ Select **Drive Mode** in the main menu
- ▶ Select **Single** or **Continuous Low Speed** or **Continuous High Speed** in the submenu

Once you have selected your setting, the camera will take serial exposures as long as you keep the shutter button pressed down fully and you have sufficient space on your memory card. Tapping the shutter button will take single shots instead.

Notes

- The specified picture frequency and the max. number of pictures in a series refer to a default setting (**ISO 200**, JPG format **L-JPG**). With other settings or depending on the picture content, **White Balance** setting and the memory card used, the frequency and number may vary.
- Regardless of how many pictures were taken in a series, the last picture in the series or the last picture in the series or the last picture saved on the memory card while the saving process is ongoing will be displayed first in both review modes.

INTERVAL SHOOTING

This camera allows you to capture motion sequences over extended periods of time automatically using the interval shooting function. You must specify the interval between shots and the number of frames in the series.

SPECIFYING THE NUMBER OF PICTURES

- ▶ Select **Drive Mode** in the main menu
- ▶ Select **Interval** in the submenu
- ▶ Select **Frames**
 - A keyboard submenu will appear (s. page 43).
 - Any new setting entered via the keyboard submenu will overwrite any previously set number.
 - The first position of the entry line is marked as “ready for editing” (that will be the value **1000** in the factory setting). You can enter a number between 1 and 9999.

SPECIFYING THE INTERVALS BETWEEN SHOTS

- ▶ Select **Drive Mode** in the main menu
- ▶ Select **Interval** in the submenu
- ▶ Select **Interval Time**
- ▶ Select the desired interval between shots
- ▶ Press down the shutter button to start the series

Notes

- A running series of pictures can only be aborted by switching off the camera. The relevant settings remain unchanged, which means that tapping the shutter button again after switching the camera on will restart the series.
 - Live View can only be used for a short period of time with interval shooting: It is switched off again after each individual picture. The camera may switch off and on again if "Auto power off" is set and no other camera operation occurs between the individual shots.
 - Interval shooting over an extended period of time in a cold location or in a place with high temperature and humidity may result in malfunctions.
 - Interval shooting will be interrupted or canceled in the following situations:
 - if the battery is depleted
 - if the camera is switched offMake sure to use a sufficiently charged battery.
 - Interrupted or canceled interval shooting can be resumed by switching the camera off, replacing the battery or memory card as needed and then switching the camera back on. The pictures taken after function interruption will be stored in a separate group.
 - The interval function remains active after a picture series is completed, and also after the camera is switched off and on again. You will have to change functions in the **Drive Mode** submenu if you want to exit the mode. A prompt will be displayed on screen if the camera is switched off and on again while the **Interval** shooting function is active.
 - The availability of this function does not mean that the camera is suitable for use as a monitoring device.
 - The pictures of an interval shoot are marked **???** in review mode.
- Regardless of how many pictures were taken in a series, the last picture in the series or the last picture in the series or the last picture saved on the memory card while the saving process is ongoing will be displayed first in both review modes.

SELF-TIMER

You can use the self-timer to take a picture with a delay of either 2 or 12 s. This is useful for group photographs in which you want to be included or if you want to avoid blurring caused by an unsteady hand.

We recommend that the camera is placed on a tripod.

- ▶ Select **Drive Mode** in the main menu
- ▶ Select **Self Timer 2s** or **Self Timer 12s** in the submenu, depending on which delay time you want.
- ▶ Shutter release
 - A flashing LED at the front of the camera counts down the first 10 s time delay if 12 s delay were selected. The same countdown is shown in the LCD panel.
 - The self-timer function can be canceled at any time while the 12 s are counting down by pressing the **MENU** button – the relevant setting remains intact and can be restarted by tapping the shutter button.

Note

In self-timer mode, the exposure value is set just before the picture is taken and not when the shutter button is pressed.

FLASH PHOTOGRAPHY

The camera determines the necessary flash intensity by firing one or more ranging flashes, fractions of a second before taking the actual picture. The main flash fires immediately after to enable exposure. All factors influencing the exposure (e.g. filters, aperture settings, distance to the main subject, reflective ceilings, etc.) are automatically considered.

COMPATIBLE FLASH UNITS

The following flash units enable all Leica M10-P functions described in this manual:

- Leica system flash units like the models SF 26, SF 40, SF 60, SF 64.
- Other Leica system flash units (exception: Leica SF 20)
- Other commercially available flash units with a standard flash foot and positive center contact ¹ (fired by the center/X contact).
- Studio flash units (fired via synchronization cable)

Note

We recommend the use of state-of-the-art thyristor-controlled electronic flash units.

¹The **Flash** setting should be used if flash units are used that are not specially designed for the camera and do not automatically adjust the white balance on the camera.

ATTACHING THE FLASH UNIT

- ▶ Switch off the camera and flash unit
- ▶ Slide the foot of the flash unit all the way into the accessory shoe and use the clamping nut (where available) to secure it against accidental detaching.
 - Movement inside the accessory shoe can interrupt required contacts and therefore cause malfunctions.

Notes

- The camera and flash unit must be switched off before the connection is made.
- Make sure that the accessory shoe cover is always in place when no accessory is attached (e.g. a flash unit).

FLASH EXPOSURE METERING (TTL METERING)

The camera offers a fully automated, camera-controlled flash mode in conjunction with the system-compatible flash units (see p. 77) for the two exposure modes aperture priority and manual setting.

An additional brightening control is provided. However, if the ambient brightness at the shortest possible flash sync time of 1/180 s would result in overexposure, then only a HSS-compatible flash unit will fire in aperture priority mode. Where that is the case, the shutter speed will be controlled in accordance with ambient light conditions and displayed in the viewfinder.

In aperture priority mode and with manual setting, the camera also allows the use of additional flash techniques like flash synchronization and firing with slower shutter speeds than the sync time 1/180 s, which may be interesting in terms of picture composition. These functions are set on the camera via the menu (please read the next sections for more information).

The camera additionally communicates the sensitivity setting to the flash unit. The flash unit can use this information to automatically adjust its range data, provided the device comes with these displays and the aperture setting selected on the lens is also entered manually on the flash unit. The ISO sensitivity setting cannot be altered via the flash unit on system-compatible units, because the information is received from the camera.

Notes

- Studio flash systems may have a very long flash firing duration. It may therefore be advantageous to select a slower shutter speed than 1/180 s when using such a system.
- The same applies for RF-controlled flash firing for so-called "off-camera" flashes, because they may have a certain time delay due to RF transmission.
- The settings and functions described in the following sections only apply to settings and functions available in this camera and in system-compatible flash units.
- An exposure compensation setting (see p. 69) on the camera will only affect the measurement of ambient light. Additional settings on the flash unit will be required if you want to simultaneously use compensation of the TTL flash exposure metering in flash mode (parallel or opposed). (Exception: On the Leica SF 26, corrections must be set on the camera via menu control.)

Please read the relevant instructions provided with the device for more information about flash use and the various available flash modes when using flash units that are not designed specifically for this camera.

FLASH MODES

AUTOMATIC (A)

- ▶ Switch on the flash unit
- ▶ Set the desired guide number control mode (e.g. TTL or GNC = Guide Number Control) on the flash unit
- ▶ Switching the camera on
- ▶ Tap the shutter button before each flash exposure to activate exposure metering
 - The flash unit may not fire if this step is missed by pressing the shutter button down completely and skipping these settings.
- ▶ Set the desired exposure mode, shutter speed and/or aperture setting
 - Take note of the shortest flash sync speed, as it determines whether a "normal" flash or an HSS flash is fired.

HSS (HIGH SPEED SYNC.)

AUTOMATIC FLASH ACTIVATION FOR **FAST** SHUTTER SPEEDS

A fully automated, camera-controlled HSS flash mode for all shutter speeds and all exposure modes is available in the Leica M10-P when used with system-compatible flash units (see p. 77). It is activated by the camera automatically if the selected or calculated shutter speed is faster than the sync speed (1/180 s).

Note

The range for HSS flashes is significantly lower than for TTL flashes.

FLASH CONTROL

FLASH RANGE

(SELECTING THE SYNC SPEED / SYNC SPEED RANGE)

Reproduction of the available light is determined by the shutter speed and the aperture. With a permanent setting of the shortest possible shutter speed for flash operation (sync time), an unnecessary, more or less severe underexposure of all subject elements not correctly lit by the flash will occur in most situations.

The Leica M10-P allows you to fine tune the shutter speed used in flash mode in combination with Aperture Priority depending on the conditions of the subject or your own picture composition ideas.

- ▶ Select **Flash Settings** in the main menu
- ▶ Select **Max. Flash Sync. Time** in the submenu
- ▶ In the submenu, select one of the three automatic focal length-specific settings (**1/f**, **1/(2f)**, **1/(4f)**) or the desired slowest shutter speed

Notes

- The **1/f** setting results in the slowest shutter speeds based on the rule of thumb for blur-free pictures taken manually, e.g. 1/60 s using a 50 mm lens. The shutter speeds with **1/(2f)** and **1/(4f)** would in this example be 1/125 s and 1/250 s respectively.
- All shutter speeds up to sync time (1/180 s) can be set via manual exposure control.

SYNC POINT

Flash exposures are lit by two light sources:

- ambient light
- the flash

Any subject elements lit primarily by the flash will almost always be rendered in perfect focus by the short burst of light, provided the sharpness is set correctly. All other subject elements in the same frame lit by ambient light or lit from within will be rendered with varying degrees of sharpness. Whether or not these subject elements will be rendered in sharp focus or blurred and the degree of blurriness all depends on two interdependent factors:

- The shutter speeds
- The speed of motion of the subject elements or camera at the time of exposure

The longer the shutter speed and the faster the motion, the greater the difference between the two superimposed partial images.

The conventional time for firing the flash is at the start of exposure (right after the 1. shutter curtain has completely opened the image window). This may result in apparent contradictions, e.g. the picture of a vehicle being overtaken by its own light trail.

The Leica M10-P allows you to select the time of the flash: either at the start of the exposure time or synced with the end of the exposure phase, just before the second shutter curtain (i.e. when the image window closes again.) The sharp image will in this case be a rendering of the captured motion. This flash technique creates a more natural impression of movement and dynamics in the image.

This function is available with all camera and flash unit settings.

- ▶ Select **Flash Settings** in the main menu
- ▶ Select **Flash Sync. Mode** in the submenu
- ▶ Select the desired variant
(**Start of Exp.**, **End of Exp.**)

FLASH EXPOSURE COMPENSATION

This function can be used to selectively reduce or strengthen the flash exposure regardless of the exposure from available light, e.g. in a picture taken in the evening or to brighten the face of a person in the foreground while retaining the same lighting ambience.

- ▶ Select **Flash Settings** in the main menu
- ▶ Select **Flash Exposure Compensation** in the submenu
 - The submenu displays a scale with a red setting mark. The function is deactivated if the value is set to 0.
- ▶ Set the desired value
 - The initial menu list shows a correction set via **EV+X**¹.

Notes

- The menu item **Flash Exposure Compensation** can only be used in conjunction with flash units on which the correction value cannot be set manually (e.g. Leica SF 26). The settings on the scale in the camera menu can therefore only be confirmed if a suitable flash unit is connected and switched on.
- A brighter flash illumination with Plus correction will require a stronger flash and vice versa. Flash exposure compensation will therefore impact on the flash range: A Plus correction will decrease it, a Minus correction will increase it.
- Once set, compensation remains active until it is reset to 0, no matter how many pictures are taken and even after the camera is switched off.

¹ Example (Plus or Minus): "X" stands for the relevant value.

FLASH EXPOSURE DISPLAYS IN THE VIEWFINDER (SYSTEM-COMPATIBLE FLASH UNITS)

The flash icon in the viewfinder display of the Leica M10-P reports and indicates various operating states.

<p>⚡ does not appear (despite the flash unit being switched on and ready)</p>	<ul style="list-style-type: none"> • The flash unit cannot fire • A correct operating mode must be set on the flash unit or an HSS-compatible flash unit must be connected
<p>⚡ <u>flashes</u> slowly before the picture is taken (2 Hz)</p>	<ul style="list-style-type: none"> • The flash unit is not yet ready for use
<p>⚡ <u>lights up</u> before the picture is taken</p>	<ul style="list-style-type: none"> • The flash unit is ready for use
<p>⚡ <u>remains</u> continuously lit after firing*</p>	<ul style="list-style-type: none"> • The flash is still ready
<p>⚡ <u>flashes</u> rapidly after taking the picture (4 Hz)*</p>	<ul style="list-style-type: none"> • Successful flash photography • The flash unit is not yet ready for further use
<p>⚡ switches off after firing*</p>	<ul style="list-style-type: none"> • Flash intensity was insufficient

*only in TTL flash mode

PLAYBACK/REVIEW MODE

Picture review mode

- There is no time limit for reviewing pictures
- Short-term rendering of the picture on the display directly after exposure (**Auto Review**)

PICTURE REVIEW

- ▶ Press the **PLAY** button
 - The picture taken last is displayed first with its relevant settings.
 - The following message appears if the inserted memory card does not contain any picture data: **No media file to display**
 - Pressing the **PLAY** button may cause different responses, depending on the previously set function:

Initial situation	After pressing the PLAY button
Full screen display of a picture	Picture mode
Display of an enlarged picture section/or several thumbnails	Full screen display of the picture

AUTOMATIC REVIEW OF THE MOST RECENT PICTURE TAKEN

The **Auto Review** function allows you to view each picture right after it was taken. That allows you to check whether the shot was successful or should be taken again. The function additionally allows – possibly in conjunction with the shutter button – to set the length of time the picture will be displayed.

- ▶ Select **Auto Review** in the main menu
- ▶ Select the desired function or the duration (**Off**, **1s**, **3s**, **5s**, **Permanent**) in the submenu

Note

The picture will remain on the display if the shutter button is still held down fully after the picture is taken. This function is not available if **Off** is selected.

You can switch back from **Auto Review** mode to the standard review mode without time limit at any time.

Note

Both review modes show the last picture in the series or the last picture in the series saved on the currently active card while saving is still ongoing if pictures were taken using the bracketing/interval function. Details of how to select the other pictures in the series and further options in review mode are described in the following sections.

DISPLAYS IN PLAYBACK/REVIEW MODE

With the factory settings in place, the shot will be displayed in review mode without the information in the header and footer lines to allow an unobstructed view of the entire image.

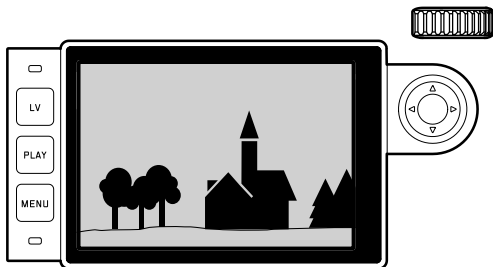

You can call up the header and footer lines at any time.



Using gesture control

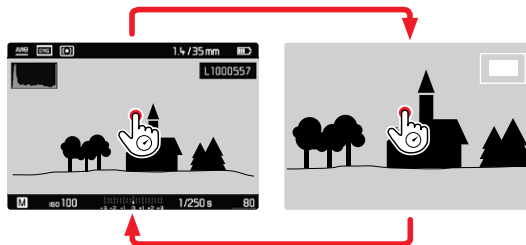

Using button control

- ▶ Press the center button
 - Where the functions **Histogram** and **Clipping** are activated, these displays will appear as well.

Notes

- The histogram and the clipping indicators are available when viewing both the entire picture and a section of it, but not when simultaneously viewing 12 or 20 reduced pictures.
- The histogram and clipping displays always refer to the currently shown picture section.

SELECTING/SCROLLING THROUGH PICTURES

Press the directional pad to the left or right to access other saved pictures. Once the first/last picture is viewed, the image series starts again in an endless loop accessible in both directions. The picture numbers change accordingly.

Using gesture control

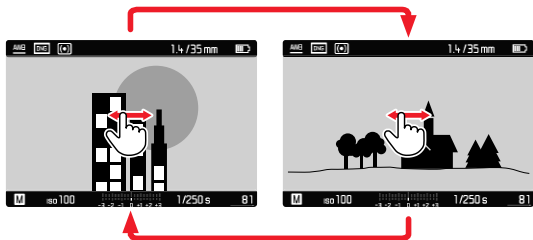

Using button control

- ▶ Press the directional pad to the left or right

Notes

- Swiping to the right (gesture) or pressing the directional pad will result in a playback of pictures/recordings with higher numbers; the same commands to the left will play back the lower number pictures.
- The pictures/recordings are displayed in an endless loop in either direction. Once the last picture/recording is reached, the first will appear again.

ENLARGED CROPPED SECTION

You can enlarge a cropped section of a picture anywhere in the frame for closer inspection. Magnifications up to 1:1 are available, i.e. 1 pixel of the picture renders up to 1 pixel on the display.

Using gesture control

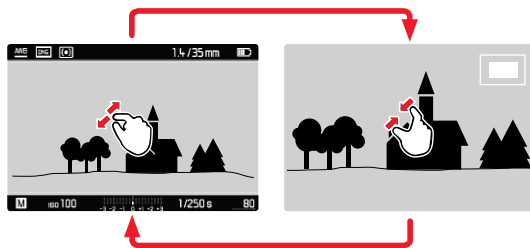

- ▶ Two-finger pinch/spread
 - The central section of the picture is magnified.



- ▶ Swiping will allow you to move the position of an enlarged cropped section
 - The rectangle within the frame in the bottom left corner represents the magnified section, as well as its position in the image.

Using button control

- ▶ Turn the thumbwheel to the right
 - The central section of the picture is magnified.
- ▶ Press the directional pad to move the enlarged section anywhere in the image
 - The rectangle within the frame in the bottom left corner represents the magnified section, as well as its position in the image.

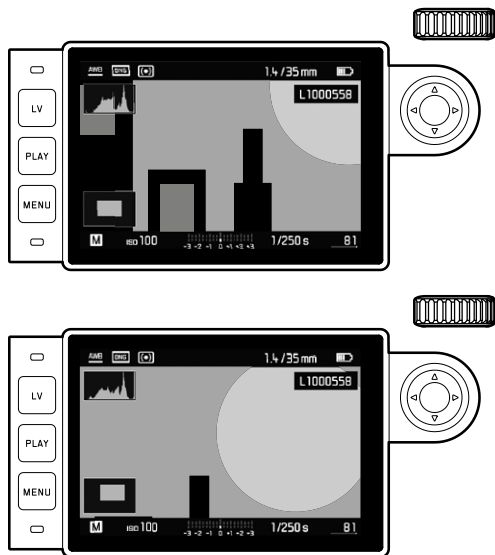

Note

You can move directly from one picture to the next in magnification mode, with the next image shown at the same magnification. Simply press the direction pad to the left or right – while holding down the **PLAY** button.

DISPLAYING SEVERAL PICTURES AT ONCE

You can view up to 20 pictures at once to e.g. get an overview or to find a specific picture.

Using gesture control

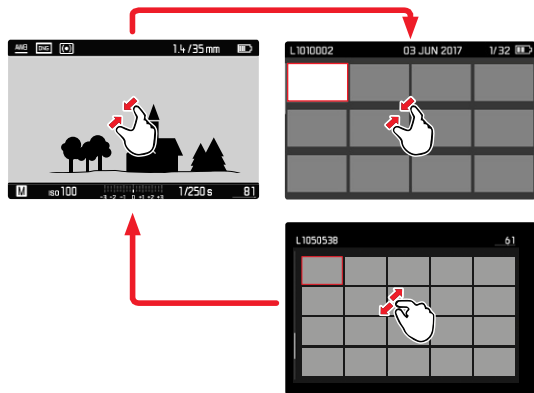

Using thumbwheel control

- ▶ Turn the thumbwheel to the left
 - 12 pictures are shown at the same time. Another turn on the thumbwheel increases the number of pictures to 20.

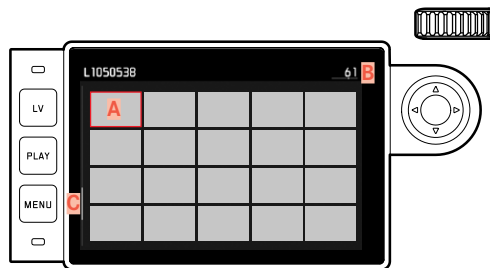

- A** Picture
- B** Image number of the currently viewed picture (red)
- C** Scrollbar

- To navigate between pictures:
 - ▶ Press the directional pad left or right as needed
 - the currently viewed picture is framed in red and can be selected for a closer look.
- To show the picture in standard size:

Using gesture control

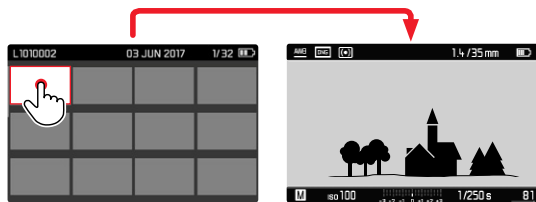

Using thumbwheel control

- ▶ Turn the thumbwheel to the right or press the **PLAY** button
- To view blocks of 20 pictures:
 - ▶ Turn the thumbwheel to the left until the entire field is framed in red
 - This function speeds up scrolling.

PICTURE MARKING/UNMARKING

Any picture can be marked to e.g. find it again quicker or to facilitate a simultaneous deletion of multiple pictures (see next section). Marking can be done directly, or via menu control.

MARKING A PICTURE

Using button control

- ▶ Press the directional pad up
 - The picture is marked with ★.

Using menu control

- ▶ Press the **MENU** button

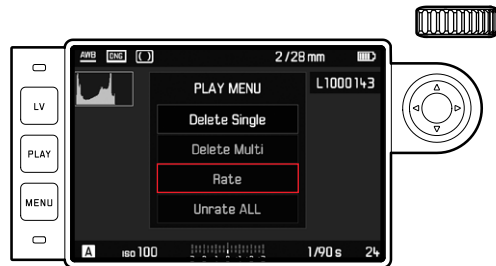

- ▶ **Select** Rating
- ▶ Press the center button
 - The picture is marked with ★.

PICTURE UNMARKING

Using button control

- ▶ Press the directional pad up
 - The  marking disappears.

Using menu control

- ▶ Press the **MENU** button

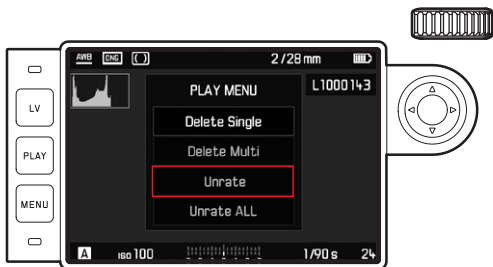

- ▶ Select **Unrate** or **Unrate ALL**
 - The LED will flash during this operation.
- ▶ Press the center button

DELETING A PICTURE

When reviewing a picture you have the option to delete it immediately. This can be useful, e.g. if the picture was already saved to other media, if you no longer want it or if you need to free up space on the memory card. You can optionally delete one, several or all pictures simultaneously (marked pictures cannot be deleted).

- ▶ Press the **MENU** button
 - The delete menu appears.

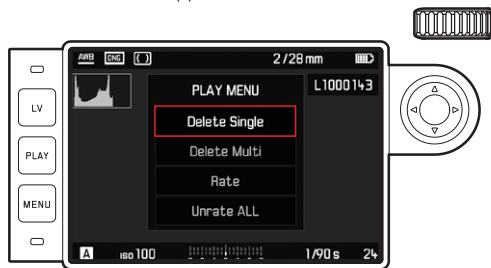

DELETING INDIVIDUAL PICTURES

- ▶ Select **Delete Single**
- ▶ Press the center button
 - The LED will flash during the delete process.
 - The next picture appears once deletion is completed. The following message appears if no other pictures are saved on the card: **No media file to display.**

DELETING MULTIPLE/ALL PICTURES

- ▶ Select **Delete Multi**
- ▶ Press the center button
- ▶ Select the required option **ALL** or **ALL unrated** in the submenu (see section above). Select **No** if you don't want to delete any pictures after all.
 - A prompt to confirm the selection of **ALL** or **ALL Unrated** will appear to safeguard against accidental deletion.
- ▶ Select **YES**
 - The LED will flash during the deletion process. The next marked picture appears once deletion is complete. The following message appears if no other pictures are saved on the card: **No media file to display.**

Notes

- Marking and deletion is only possible in **PLAY** review mode. The processes are, however, not affected by whether a picture is displayed in standard size or if several pictures are shown as thumbnails (that doesn't apply if the red frame encompasses the entire picture group when 20 thumbnails are displayed simultaneously).
- You can still select other pictures while the deletion and marking menu is activated.
- You can exit the deletion menu at any time by pressing the **PLAY** button.
- When a picture is deleted, the following pictures are renumbered as follows: When you delete – let's say Picture 3 – then the former Picture 4 will be assigned the number 3, the former Picture 5 gets number 4, etc. This renumbering does not apply to the file numbers on the memory card.

OTHER FUNCTIONS

USER PROFILES

This camera allows the permanent storage of any menu setting combinations, to e.g. access them quickly and easily for recurring conditions/image subjects. For memory slots are provided to store custom settings, plus the factory setting, which is always available and cannot be modified. You can change the names of the saved profiles.

Any profiles configured for the camera can be saved to a memory card for use on other cameras. Similarly, profiles saved on a memory card can be transferred to the camera.

SAVE CURRENT SETTING AS USER PROFILE

CREATING PROFILES

Saving settings/Creating a profile

- ▶ Create custom settings for the desired functions via menu control
- ▶ Select **User Profiles** in the main menu
- ▶ Select **Save as User Profile** in the submenu
- ▶ Select a memory slot
- ▶ Confirm the selection

RENAMING PROFILES

- ▶ Select **User Profiles** in the main menu
- ▶ Select **Rename User Profiles** in the submenu
- ▶ Select a profile
- ▶ Enter a name for the profile via the associated submenu keyboard and confirm your input (see p. 43)

APPLY/ACTIVATE PROFILE

- ▶ Select **User Profiles** in the main menu
 - The names of saved, active user profiles appear in white.
- ▶ Select **Load Profile** in the submenu
- ▶ Select a profile
 - The **Standard Profile** is selected by default
 - The selected profile is marked as **active**.
 - Free memory slots appear in gray.

Note

 will appear in the original menu list instead of the name of the profile used if you change one of the settings for the profile currently in use.

EXPORTING/IMPORTING PROFILES TO/FROM THE MEMORY CARD

- ▶ Select **User Profiles** in the main menu
- ▶ Select **Export to Card** or **Import from Card** in the submenu
- ▶ Confirm the selection

Note

During profile imports/exports, all 4 memory slots are transferred to/from the memory card, including free slots. Any existing profiles stored in the camera will be overwritten/deleted during a profile import.

DATA MANAGEMENT

DATA STRUCTURE ON THE MEMORY CARD

FOLDER STRUCTURE

The files (= pictures) on the memory cards are saved in automatically generated folders. The first three characters signify the folder number (numerals), the last five the folder name (letters). You can change the numbers and the letters when you create a new folder. By default, the first folder is named "100LEICA", the second "101LEICA", etc. The folder number will be the next available number; you can have max. 999 folders.

FILE STRUCTURE

The file names in these folders consist of eleven characters. By default, the first file is named "L1000001.XXX", the second "L1000002.XXX", etc. "L" stands for the camera brand; you can change the next three characters at any time - numerals or letters can be used. The second group of numbers is the file number: "XXX" stands for the file format (DNG or JPG). If the folder currently in use contains file number 9999, then a new folder is created, in which the file numbering begins at 0001 again.

Notes

- When using memory cards that were not formatted with this camera, the file numbering will begin with 0001 again. Should the memory card already contain a file with a number higher than the last number assigned by the camera, then numbering will be continued from the relevantly highest number on that card.
- A relevant message will be displayed, once folder number 999 and file number 9999 are reached, and all numbering must be reset.

CHANGING FILE NAMES

- ▶ Select **Image Numbering** in the main menu
- ▶ Select **Change Filename** in the submenu
 - A keyboard submenu is displayed.
 - The input line contains the full file name. The three white numerals in the first group can be changed.
- ▶ Delete the three selected characters
- ▶ Enter a new name of your choice (see p. 43)
- ▶ Confirm

Notes

- The change to a file name applies for all later pictures as well until a new change is made. The sequential number (second 4-digit group of numerals) will not be affected by the change; it can, however, be reset by creating a new folder (see previous page).
- When all user-affected changes are reset, then the file name will once again be “L100XXXX.XXX”.

CREATING A NEW FOLDER

- ▶ Select **Image Numbering** in the main menu
- ▶ Select **New Folder** in the associated submenu.
 - A keyboard submenu is displayed.
 - The input line contains the full folder name. The five white characters can be modified.
- ▶ Delete the five selected characters
- ▶ Enter a name of your choice
- ▶ Confirm
 - A prompt appears. Here you decide if you want the file numbers in the new folder to start at 0001 again (**Yes**) or if the numbering should continue (**No**).

Notes

- A file name change also applies to all subsequent folders or until another change is made.
- When all user-affected changes are reset, then the folder name will once again be “XXXLEICA”.
- You can create a new folder at any time.

RESETTING IMAGE NUMBERING

- ▶ Select **Image Numbering** in the main menu
- ▶ Select **Reset Image Numbering** in the submenu
 - A relevant prompt is displayed.
- ▶ Confirm the creation of a new folder (**Yes**) or cancel the new folder (**No**).

Note

The name part of a new folder created using **Reset** remains unchanged. The file numbers in the folder will start again at 0001.

COPYRIGHT MARK



This camera allows you to enter letters and other characters as a copyright mark for your picture files.

You can enter up to 20 characters of information under 2 headings per picture.

- ▶ Select **Camera Information** in the main menu
- ▶ Select **Copyright Information** in the submenu
- ▶ **Activate the Copyright** function (**On**)
- ▶ Select **Information/Artist** in the submenu
 - A keyboard submenu is displayed.
- ▶ Enter the desired information (see p. 43)
- ▶ Confirm

RECORDING THE PICTURE LOCATION WITH GPS

The GPS (global positioning system) allows the pinpointing of a receiver anywhere in the world. When the function is activated the Leica M10-P continuously receives the corresponding signals and updates the position data. It can write this information - latitude and longitude, height above sea level - to the "EXIF" data. Please read "Important notes regarding the use of GPS" (see p. 6) before you activate this function.

- ▶ Select **GPS** in the main menu
- ▶ Function activation (**On**) or deactivation (**Off**)
 - The "satellite" icon in the top display indicates the current status:
 -  most recent geolocation max. 6 min. ago
 -  most recent geolocation max. 24 hrs ago
 -  no geolocation data available

FORMATTING A MEMORY CARD

Memory cards that have already been in use with this camera will usually not require formatting. An unformatted memory card that is inserted into the camera for the first time will have to be formatted. We recommend formatting memory cards from time to time, because residual data traces (data pertaining to individual pictures) may reduce the card's memory capacity.

- ▶ Select **Format SD** in the main menu
- ▶ Confirm the selection

Notes

- Never switch off the camera while data transfer is in progress.
- All data stored on a memory card will be lost during formatting. Formatting will not be prevented by the deletion protection set for individual pictures.
- Make it a habit to transfer all pictures to a safe storage location (e.g. the hard drive of your PC) at your earliest convenience.
- A simple formatting process will initially not irretrievably destroy existing data on the card. Only the directory will be deleted, which means the data will no longer be directly accessible. Data access can be restored with appropriate software. Only data subsequently overwritten when new data is saved will actually be irretrievable.
- Make sure to reformat the memory card in your camera if it was originally formatted in another device, e.g. a computer.
- Contact your retailer or Leica Customer Care if the memory card cannot be formatted/overwritten.

-

DATA TRANSFER

The picture data on a memory card can be transferred to a computer via a card reader for SD/SDHC/SDXC cards.

WORKING WITH RAW DATA (DNG)

You will need specific software for editing data in DNG format, e.g. the professional raw data converter Adobe® Photoshop® Lightroom®. It allows high-quality conversions of stored raw data. It furthermore provides quality-optimized algorithms for digital color processing, delivering exceptionally low-noise photographs with incredible resolution.

During editing, you can adjust parameters like gradation, sharpness etc. in retrospect to achieve the best possible image quality.

RESETTING THE CAMERA TO FACTORY SETTINGS

This function allows you to reset all menu settings to restore the factory settings. You can choose to leave the user profiles, WLAN settings and/or the image numbers intact:

- ▶ Select **Reset Camera** in the main menu
- ▶ Confirm deletion of profile settings (**Yes**)/ decline (**No**) and/or
- ▶ Confirm reset of the image numbers (**Yes**)/decline (**No**)

Note

- You can alternatively reset the image file numbers via the menu item **Reset Image Numbering** (see p. 96)
- This reset will also affect the settings for **Date & Time** and **Language**. The camera is rebooted after it is switched off and on again, which means you will have to go through the setup process again (see p. 46).

FIRMWARE UPDATE

Leica is continuously working on the further improvement and optimization of your camera. Since many camera functions are entirely controlled by software, some of these improvements and additions to the functional scope can be installed in retrospect. Leica offers firmware updates at irregular intervals, which you can download from our website.

Leica will notify you of any new updates, once you have registered your camera.

Find out which firmware version is currently installed:

- ▶ Select **Camera Information**
- ▶ You will find the relevant version designation in the submenu **Camera Firmware**

More information about registering, firmware updates and their downloads for your camera, as well as any amendments and additions to the details provided in this manual can be found in the customer area of our website at: <https://owners.leica-camera.com>

Notes

- The message **Battery low** will appear if the battery is not sufficiently charged. Please recharge the battery and then repeat the process described above.
- Make sure to follow all the instructions regarding the re-commissioning of your camera.

REMOTE CAMERA CONTROL (WLAN)

You can control your camera remotely using a smartphone/tablet PC. You will need to install the Leica app on your smartphone. This app is available in the Apple App Store™ for iOS™ devices.

CONNECTION METHOD

There are two options for establishing a connection between your camera and your smartphone/tablet PC.

- With **WLAN** availability:
the **Join WLAN** method is recommended.
- With **no** WLAN availability:
establishing a wired connection (**Create WLAN**) may be most practical.

Note

The WLAN function automatically deactivates after 2 mins if no connection is established with the Leica app or the router or 30 s after the app is deactivated.

ABOUT JOINING A WLAN (**Join WLAN**)

Access to the available Wifi networks is possible with this function. When using this method, the camera and the smartphone/tablet PC will be registered on the same WLAN network.

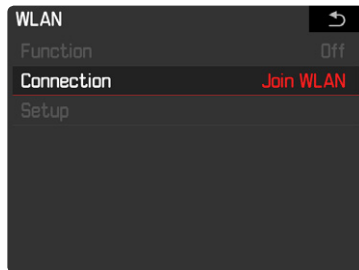

- ▶ Select **WLAN** in the main menu
- ▶ Activate **(ON) Function** in the submenu
- ▶ Select **Connection** in the same submenu
- ▶ Select **Join WLAN**
- ▶ Select **Configuration** in the same submenu
 - The camera automatically lists the available networks.
- ▶ Select the desired WLAN from the network list or enter a hidden network via the **Add network** option
 - The keyboard submenu is displayed.
- ▶ Press the center button to confirm the selected network

DIRECT CONNECTION WITHOUT WLAN (Create WLAN)

This function allows access to the camera without an available WLAN network.

In this method, the camera generates an access point for registering your smartphone/tablet PC.

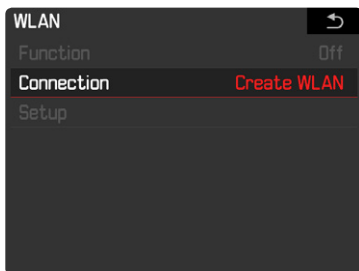

- ▶ Select **WLAN** in the main menu
- ▶ Activate **(ON) Function** in the submenu
- ▶ Select **Connection** in the same submenu
- ▶ Select **Create WLAN**

CREATE PERSONAL PASSWORD

For security reasons, you should change the predefined password for the connection to your Leica M10-P. The data is encrypted with the WPA2 standard during the data exchange.

- ▶ Select **WLAN** in the main menu
- ▶ Select **Configuration** in the submenu
- ▶ Enter the desired **Password**
 - The keyboard submenu is displayed.
- ▶ Confirm

CHANGE DEVICE NAME (SSID)

You can change the device name (SSID) of the camera.

- ▶ Select **WLAN** in the main menu
- ▶ Select **SSID/Network Name** in the submenu
 - The keyboard submenu is displayed.
- ▶ Enter a name of your choice
- ▶ Confirm

CARE/STORAGE

CAMERA HOUSING

- Keep your equipment meticulously clean, as any kind of dirt residue represents a breeding ground for micro organisms.
- Only clean the camera with a soft, dry cloth. Stubborn dirt should first be moistened with a watered-down detergent and can then be wiped away with a dry cloth.
- Wet a soft cloth with tap water, wring it out thoroughly and wipe the camera clean of any salt water spray. Then wipe it down thoroughly with a dry cloth.
- Wipe the camera with a clean, lint-free cloth to remove stains and fingerprints. Tougher dirt in hard to reach corners of the camera housing can be removed with a small brush. Take care not to touch the shutter blades.
- Store the camera in a closed and padded container to prevent friction damage and protect it against dust accumulation.
- Keep the camera in a dry, sufficiently ventilated place, where it will not be subjected to high temperatures and humidity. Make sure to remove all moisture from the camera if it was used in humid conditions.
- Do not store the camera in a leather case for extended periods of time to prevent fungal contamination.
- Empty your camera bag completely if it ever gets wet during use. Your equipment might otherwise be subjected to moisture and tanning agents released by the moist leather.
- All mechanical bearings and sliding surfaces on your camera are lubricated. Remember to press the shutter button several times every three months to prevent the lubrication points hardening if the camera will not be used for an extended period of time. We also recommend repeated adjustment and use of all the other operating elements.

- When using your camera in tropical climates, make sure to expose the equipment to sunlight and fresh air as much as possible to prevent fungal growth. Storage in airtight containers or cases is recommended only in conjunction with a desiccant like silica gel.

LENS

- A soft-bristle brush will usually suffice to remove dust from the outer lenses. Remove more severe soiling with a clean, soft cloth that is completely free of foreign matter. Wipe the lens in a circular motion from the center outward. We recommend using microfiber cloths that come in a protective container and are offered at photography shops and other optical retailers. These cloths are machine-washable at 40°C. Do not use softener and do not iron the microfiber. Never use spectacle lens cleaning cloths, as these are soaked in chemicals, which could damage the glass of the camera lenses.
- Attach a transparent UVA filter for optimal front lens protection in unfavorable conditions (e.g. sand, salt water spray). Please remember that the filter may create unwanted light reflections in some backlight situations and in case of high contrasts.
- The lens caps supplied protect the lens against accidental fingerprint smudges and rain.
- The bayonet is lubricated ex works with an ultra fine grease film to ensure smooth lens changes. Under normal conditions, this lubrication will remain intact for many years and even if the bayonet is wiped clean from time to time. The lubrication will have to be renewed after a degreasing agent was used for cleaning. Simply dab a bit of Vaseline onto the bayonet with your finger and use a clean cloth to rub it evenly and thinly all over.

- Make sure not to apply too much lubricant to the bayonet and take particular care not to apply grease to the 6-bit encoding. Too much lubricant will result in grease residue lodging in the gap, where dirt will accumulate. The legibility of the code will be impacted, which may cause malfunctions in digital M models.
- All mechanical bearings and sliding surfaces on your lens are lubricated. Make sure to move the focus ring and the
- Aperture setting ring periodically to prevent seizing if the lens will not be used for an extended period of time.

LCD PANEL

- Switch off your camera and leave it to stand at room temperature for around 1 hour if condensation has formed on or in the camera. The condensation will disappear, once the camera temperature has reached room temperature.

RECHARGEABLE BATTERY

- Remove the rechargeable battery if the camera will not be used for an extended period of time, as the date and time setting will be lost latest after 2 months.
- Lithium-ion rechargeable batteries should only be stored partially charged, i.e. not fully depleted or fully charged. The camera LCD panel will show the current charge level of the battery. Charge the battery twice a year for around 15 minutes to avoid deep discharge in case of very long storage periods.

MEMORY CARDS

- Make sure to store memory cards in their anti-static container when not in use.
- Do not store memory cards where they will be exposed to high temperatures, direct sunlight, magnetic fields or static electricity. Always remove the memory card if the camera will not be used for an extended period of time.
- We recommend formatting the memory card from time to time, because fragmented residual data from deleted files may block some of its storage capacity.

SENSOR

DUST DETECTION

Any dust or dirt particles stuck to the glass cover of the sensor may result in noticeable dark spots or specks on the pictures. Use the **Dust detection** function to check if and how much dust is on the sensor. This procedure is more accurate than a visual check and therefore a reliable method to find out if cleaning is needed.

- ▶ Select **Sensor Cleaning** in the main menu.
- ▶ Select **Dust detection** in the submenu
 - The following message appears: **Please close the aperture to the largest value (16 or 22), and take a picture of a homogeneous surface (defocussed)**
- ▶ Press the shutter button
 - A "picture" will appear on the display, in which black pixels represent dust particles.

Note

A relevant message will be displayed if dust detection is not available. The display will return to the previous screen after a few seconds. Repeat the process as needed.

SENSOR CLEANING

- Any inspection or cleaning of the sensor should be done in an environment that is as much as possible dust-free to prevent further contamination.
- Use clean, possibly ionized gases like air or nitrogen to blow loose dust from the cover glass of the sensor. We recommend using (rubber) bellows without a brush. Some specialist, low-pressure cleaning sprays, e.g. "Tetenal Antidust Professional" can also be used (follow the instructions provided for the product).
- Please contact Leica Customer Care if you are unable to remove the particles with the methods described above.
- A message will appear on the LCD panel, once the capacity of the rechargeable battery falls below 40% with the lens aperture fully open: **Please stop sensor cleaning immediately.** The shutter will automatically close when the camera is switched off.
- Make sure that the aperture is unobstructed and that nothing can prevent the shutter from closing correctly, as this would result in damage to the equipment!

Alternatively, send your camera to the Leica Customer Care department for sensor cleaning. This service is not part of the warranty offering and will therefore incur charges. Use the **Open Shutter** menu function if you feel confident that you can do the cleaning yourself. The function will keep the shutter open and allow access to the sensor.

- ▶ Select **Sensor Cleaning** in the main menu.
- ▶ Select **Open Shutter**
 - The prompt **Inspect sensor?** will appear
- ▶ Select **Yes** or **No**
 - The rechargeable battery must have at least 60% remaining capacity for the shutter to open

Note

A warning message **Battery too low for sensor cleaning** will appear if the battery capacity is lower to indicate that the function is currently not available and **Yes** cannot be selected.

- ▶ Clean the sensor
 - Make sure you follow the instructions below.
- ▶ Switch off the camera after you finish cleaning
 - The shutter will remain open for another 10 s for safety reasons.
 - A message appears on the display **Please stop sensor cleaning immediately.**

Important

- Leica Camera AG will not accept any responsibility for damages caused by the user when cleaning the sensor.
- Do not attempt to physically blow dust particles off the cover glass of the sensor. The smallest droplets of saliva can cause stains that will be difficult to remove.
- Do not use high pressure compressed air cleaners as they may also cause damage.
- Avoid touching the sensor surface with any hard objects during inspection and cleaning.

FAQ

CAMERA	
<p>Messages:</p> <p>Battery too low for sensor cleaning Please stop sensor cleaning immediately</p>	<ul style="list-style-type: none"> - Does the battery have a sufficient charge? <i>Use a charged battery.</i> - The battery is flat. <i>Replace the battery.</i>
<p>The camera won't switch on.</p>	<ul style="list-style-type: none"> - Is the battery inserted correctly? - Does the battery have a sufficient charge? <i>Use a charged battery.</i> - Is the bottom cover inserted correctly? - Is there visible condensation? <i>This may occur when the camera is moved directly from a cold environment into heat. Wait for the camera to acclimatize and the condensation will disappear.</i>
<p>The date and time display is incorrect or not shown.</p>	<ul style="list-style-type: none"> - The camera hasn't been in use for an extended period of time and no battery was inserted. <i>Insert a fully charged battery.</i> <i>Set the date and time.</i>
RECHARGEABLE BATTERY /CHARGER	
<p>The camera switches off again immediately after it is switched on.</p>	<ul style="list-style-type: none"> - Does the battery have a sufficient charge for camera operation? <i>Charge the battery or insert a charged battery.</i>
DISPLAY	

The display is too dark or too bright.	<ul style="list-style-type: none"> - The screen image will be more difficult to see when viewing it at a wide angle. <i>The screen image is too light or too dark although you are viewing it at a perpendicular angle: Change the brightness setting.</i>
PICTURES	
The camera won't take a picture.	<ul style="list-style-type: none"> - The system is currently transferring picture data to the memory card and the cache is full. - The memory card is full and the cache is full. <i>Delete some pictures before taking new ones.</i> - No memory card is inserted and the cache is full. - The memory card is write-protected or defective. <i>Deactivate the protection or insert another memory card.</i> - Image numbering has reached its limit. <i>Reset the image numbering.</i> - The sensor is overheating. <i>Allow the camera to cool down.</i>
The picture won't save.	<ul style="list-style-type: none"> - Have you inserted a memory card? - The memory card is full. <i>Delete some pictures before taking new ones.</i>
REVIEW	
The picture I have just taken is not showing in the display.	<ul style="list-style-type: none"> - Is Auto Review activated in picture mode?
The picture won't show.	<ul style="list-style-type: none"> - Have you inserted a memory card? - The memory card is empty.

KEYWORD INDEX

6-bit encoding.....	52	Depth of field scale	22	Inserting/Removing the battery	28
Accessory.....	3	Displays on the LCD panel/in the viewfinder	23	Internal battery	12
Aperture	35	Distance	56	Interval shooting	75
Aperture priority	66	Distance metering methods.....	56/57	ISO sensitivity	60
Aperture setting.....	22	DNG resolution	50	ISO setting wheel	36
Assist function	58	Error message.....	106	ISO settings	60
Attaching/detaching the lens	33	EV level.....	69	JPG	50
Auxiliary display	73	Exposure.....	64	JPG resolution	50
Bracketing, automatic	70	Exposure compensation	69	Language.....	46
Bright-line frame	23/54	Exposure metering methods	64	LCD panel.....	24
Brightness, LCD panel/viewfinder	48	Exposure setting	66	LED	20
Bulb (B).....	36	Exposure simulation	67	Legal Notes.....	4
Capture assistants	58/73	Exposure, manual.....	67	Lens detection	52
Care	102	FAQ	106	Lenses, compatible	31
Care instructions	102	Favorites menu	39/44	Live View	56
Carry strap	26	File name	95	Long-term exposure	72
Center-weighted metering (exposure)	64	Firmware	99	LV zoom.....	44/58
Charge status (charger).....	27	Focal length	54	M lenses.....	31
Charge status (rechargeable battery).....	29	Focus assist.....	58	Magnification (picture)	86
Charger	26	Focus peaking.....	59	Main menu.....	39/40
Charger, connection.....	26	Focusing.....	56	Marking	89
Clipping	74	Focusing, manual, in Live View mode.....	57	Max. exposure time.....	61
Color saturation	51	Focusing, manual, in the viewfinder	56	Memory card	30/94/98
Color temperature.....	63	Format	94	Memory card insertion/removal.....	30
Configuration, thumbwheel.....	44	Format	50	Memory card, compatibility.....	13/30
Contrast (image properties).....	51	Formatting	97	Menu control	39
Copyright.....	96	General notes	12	Menu items.....	110
Custom settings.....	44/69	Greycard.....	62	Menu language	46
Data storage, saving to PC	98	Grid lines	74	Message	106
Data transfer.....	98	Histogram.....	73	Metering field.....	23/54/68
Delete.....	90	Home screen	41	Metering memory lock	68
		Image field.....	54	Monochrome	51
		Image properties.....	50	Monochrome photography	51

Multi-field metering (exposure)	64	Shutter button	35
Notes, legal	4	Shutter release	35
Notes, safety	8	Shutter speed	36
Open/Close the bottom cover	28	Shutter speed setting	36
Parts (camera)	20	Shutter speed setting wheel	36
Parts (lens)	22	Split image method	57
Picture magnification	58/86	Spot metering (exposure)	64
Picture sequence	75	Standby mode	47
Playback/Review display	85	Storage	102
Playback/Review mode	84	Submenu	40
Playback/Review, automatic	84	Superimposed image method	56
Power off, automatic	47	Switching off	34
Quick access	44	Switching on	34
R lenses	31	Technical data	112
Rangefinder	54	The B setting	72
Raw data	98	Thumbwheel	37
Rechargeable battery	27	Thumbwheel, configuration	44
Regulatory information	4	Time	46
Repairs	116	Time zone	47
Replacement parts	3	Troubleshooting	106
Reset	96/99	TTL metering	64
Resolution	50	User profiles	92
Safety Remarks	8	User profiles, import/export	93
Saturation	51	View (camera)	20
Scope of delivery	2	View (lens)	22
SD/SDHC/SDXC card	30/98	View angles	54
Self-timer	77	Viewfinder	54
Sensor	104/112	White balance	62
Sensor cleaning	104		
Sharpness (image properties)	51		
Sharpness setting (focusing)	56		
Short cut	44		
Shutter	20		

MENU OVERVIEW

	Factory settings FAVORITES	Available for FAVORITES
Lens Detection		●
Drive Mode	●	●
Exp. Metering		●
Exp. Compensation	●	●
Flash Settings	●	●
ISO Setup	●	● M-ISO also available
White Balance	●	●
File Format	●	●
JPG Settings	●	● JPG resolution also available
Auto Review		●
Capture Assistants		●
EVF/Display Control		●
User Profiles		● Load Profile also available
Customize Control		●
Display Brightness		●
EVF Brightness		●
Auto Power Saving		●
WLAN		●

	Factory settings FAVORITES	Available for FAVORITES
GPS ¹		●
Date & Time		●
Language		●
Reset Camera		●
Format SD card		●
Image Numbering		●
Sensor Cleaning		●
Camera Information		●

¹ This menu item is only available if the Leica Visoflex viewfinder is attached (optional accessory)

TECHNICAL DATA

Designation

Leica M10-P

Camera type

Digital camera with rangefinder system

Type No.

3656

Sensor

CMOS sensor, active surface approx. 24 x 36 mm

File formats

DNG™ (raw data, loss-free compression), JPG

Resolution

DNG™: 5976 x 3992 pixels (24 MP), JPG: 5952 x 3968 pixels (24 MP),
4256 x 2832 pixels (12 MP), 2976 x 1984 pixels (6 MP)

File size

DNG™: 20-30 MB, JPG: Depending on resolution and image content

Buffer memory

2 GB/16 pictures in series

Storage medium

SD cards up to 2 GB, SDHC cards up to 32 GB, SDXC cards up to 2 TB

LCD panel

3" color TFT LCD monitor with 16 million colors and 1,036,800 pixels, approx. 100% image field, extremely hard, scratch-resistant Gorilla® glass cover, color space: sRGB, for Live View and Playback/Review mode, displays

Switching the camera on/off

Via main switch on camera top panel, optional automatic deactivation of the electronic camera components after around 2/5/10 minutes, reactivation via a tap on the shutter button

Lens mount

Leica M bayonet with additional sensor for 6-bit encoding

Compatible lenses

Leica M lenses, Leica R lenses via adapter (see p. 31)

Menu languages

English, German, French, Italian, Spanish, Russian, Japanese, Simplified Chinese, Traditional Chinese, Korean, Portuguese

GPS

(only with Leica Visoflex viewfinder attached, optional accessory)

Optional activation (not available everywhere due to country-specific legislation, i.e. enforced automatic shutdown in those countries), data is written to EXIF header of the picture files

WLAN

Complies with IEEE 802.11b/g/n standard (standard Wifi protocol), channel 1-11, encryption method: WLAN-compatible WPA™/WPA2™ crypton, access method: Infrastructure mode

Rangefinder

Design principle

Large, bright rangefinder with bright-line frame and automatic parallax compensation

Eyepiece

Suitable for $-0,5$ dptr.; optional corrective lenses available: -3 to $+3$ dptr.

Display

Four-digit digital display with items show on the top and bottom

Image field limiter

Two lit frames: 35 mm + 135 mm, 28 mm + 90 mm, 50 mm + 75 mm (automatic switch-over when lens is attached)

Parallax compensation

The horizontal and vertical difference between viewfinder and lens is compensated automatically in line with the relevant focus setting

Congruence of viewfinder and actual image

The size of the bright-line frame matches the distance:

- at 2 m: the exact sensor size of approx. 23.9 x 35.8 mm
- at infinity: (depending on focal length) approx. 7.3% (28 mm) to 18% (135 mm)
- less than 2 m: less than sensor size

Magnification

x0.73 (all lenses)

Large-base rangefinder

Split or superimposed image rangefinder shown as a bright field at the center of the viewfinder image

Actual metering basis

50.6 mm: 69.31 mm (mechanical metering basis) x 0.73 (viewfinder magnification)

Shutter

Shutter type

Metal blade focal plane shutter with vertical movement

Shutter speeds

Aperture priority mode (A): stepless from 4 min to 1/4000 s (max. exposure only for ISO 100/200).

Manual setting: 8 s to 1/4000 s in half increments, from 8 s to 4 min in full increments.

Bulb (B): for long-term exposure up to max. 4 min. (in conjunction with self-timer T function): 1. Press shutter button = shutter opens, 2. Press shutter button = shutter closes

Picture sequence

approx. 5 pictures/s, 30-40 pictures in series (depends on a variety of setting options)

Taking the picture

Shutter button

Two-stage (1. step: Activation of the camera electronics including exposure metering and exposure lock (in aperture priority mode); 2. step: Press shutter button)

Self-timer

Delay time: 2 s or 12 s

Exposure

ISO sensitivity range

Automatic (A): ISO 200 to ISO 50000

Manual: ISO 100 to ISO 50000 (ISO 200 adjustable in 1/3 ISO increments)

White balance

Automatic (**Auto**), presets (**Daylight**, **Cloudy**, **Shadow**, **Tungsten**, **Fluorescent Warm**, **Fluorescent Cool**), one memory slot for manual measurements (**Greycard**), manual color temperature setting

Exposure metering

TTL (exposure metering through the lens), with working aperture

Metering principle/method

When measuring the light reflected by the light blades of the 1. shutter curtain onto a measuring cell: strongly center-weighted; when measuring on the sensor: Spot-weighted, center-weighted, multi-field metering

Metering range

At room temperature and normal humidity for ISO 100 at aperture 1.0 EV -1 to EV 20 at aperture 32. The LEDs in the viewfinder will flash if the metering range is undercut/overshot

Exposure modes

Aperture priority mode (A): Automatic shutter speed control with manual aperture preselection

Manual: Manual settings for shutter speed and aperture

Flash exposure control

Flash unit connector

Via accessory shoe with central and control contacts

Synchronization

Optionally at the 1. or 2. shutter curtain

Flash sync time

⚡: 1/180 s, slower shutter speeds available, automatic changeover to TTL linear flash mode with HSS-compatible Leica system flash units if sync time is undercut

Flash exposure metering

Using center-weighted TTL pre-flash metering with Leica flash units (SF 60, SF 40, SF 64, SF 26) or with system-compatible flash units via a SCA 3502 M5 adapter

Flash measuring cell

2 silicon photodiodes with converging lens in the base of the camera

Flash exposure compensation

± 3 EV in 1/3 EV increments

Displays in flash mode (in the viewfinder only)

Using flash symbol LED

Power supply

Rechargeable battery (lithium-ion battery Leica BP-SCL 5)

1 lithium-ion rechargeable battery, rated voltage 7.4 V; capacity 1100 mAh, max. charging voltage/current: 1000 mA DC, 7.4 V; operating conditions (in the camera): +0 to +40°C; manufacturer: PT. VARTA Microbattery, Made in Indonesia

Charger (Leica BC-SCL 5)

Inputs: 100-240 VAC, 50/60 Hz, 300 mA with automatic switch-over or 12 VDC, 1.3 A, output: DC, rated voltage 7.4 V, 1000 mA / max. 8.25 V, 1100 mA, operating conditions: +10 to +35°C, manufacturer: Guangdong PISEN Electronics Co. Ltd., Made in China

Camera housing

Material

Full metal housing: Magnesium die-cast, synthetic leather covering
Top cover and bottom cover: Brass, black or silver chrome-plated finish

Interfaces

ISO accessory shoe with additional control contacts for Leica flash units and Leica Visoflex viewfinder (optional accessory)

Tripod thread

A 1/4 DIN 4503 (1/4") made of stainless steel in the base

Operating conditions

0 - +40°C

Dimensions (WxHxD)

139 x 38.5 x 80 mm

Weight

approx. 675 g (with battery)

LEICA CUSTOMER CARE

Please contact the Customer Care department of Leica Camera AG for the maintenance of your Leica equipment and for help and advice regarding Leica products and how to order them. You can also contact the Customer Care department or the repair service provided by your regional Leica subsidiary for repairs or warranty claims.

Leica Camera AG

Leica Customer Care
Am Leitz-Park 5
35578 Wetzlar
Germany

Phone: +49 (0)6441 2080-189

Fax: +49 (0)6441 2080-339

Email: customer.care@leica-camera.com
www.leica-camera.com